

CAPACITIVE LEVEL CONTROLS SC - SCD SERIES



WORKING PRINCIPLE

The principle is based on the behaviour of a capacitor the capacitance of which depends on the area of the armatures in the vicinity, the distances between them and the dielectric constant of the material.

In the case of a capacitive level control the armatures of the capacitor are represented by the walls of the tank on one side and by the electrode of a probe, isolated from the walls on the other.

As the surfaces of the electrode and the walls of the tank remain constant the only variable is the material which acts as the dielectric. The dielectric constant relative to air or vacuum is 1, whilst by definition that of any other material is greater than 1, therefore by varying the quantity of material in the tank the capacitance of the capacitor is varied and this is measured by applying to the electrodes a high frequency alternating voltage and as the capacitance increases as a result in the increasing level in the tank the current flowing in the capacitor also increases.

This value of frequency current is transformed by the control circuit into a current which is used to indicate the level.

APPLICATIONS

Capacitive level controls are widely used where it is necessary to control with a good safety margin of intervention the level of substances both liquid and solid which may not be conductive.

They are particularly used in silos for cereals, foodstuffs, seeds, biscuit plants and the food industry in general.

They are also used in the transport, dosing, stocking and handling of plastic materials, petrochemical products, in foundries and cement factories.

The field of use is vast and is practically anywhere where it is necessary to control the level inside tanks which contain many types of different material.

SENSITIVITY ADJUSTMENT

After having installed the probe, if the tank is not conductive, carry out the earthing of the probe by connecting to the connector placed on the probe. In order to calibrate the sensitivity the adjustment potentiometer should be adjusted with the probe free from material until the point at which the relay switches is found and this should be noted on the potentiometer. The probe should then be immersed in the material to be controlled and the potentiometer should be adjusted once again until the relay switches, once again note the position. As a last operation place the position of the potentiometer in the mid position between the two markings. Both the SC model with incorporated power supply and the SCD model with separate power supply are supplied with a min/max level security switch which can be positioned depending on the control function that is to be carried out.

LIMITATIONS

When using capacitive probes it should be borne in mind that large deposits adhering to the probe may affect the measurement, this can however, be discounted in most cases as the probe is covered in teflon.

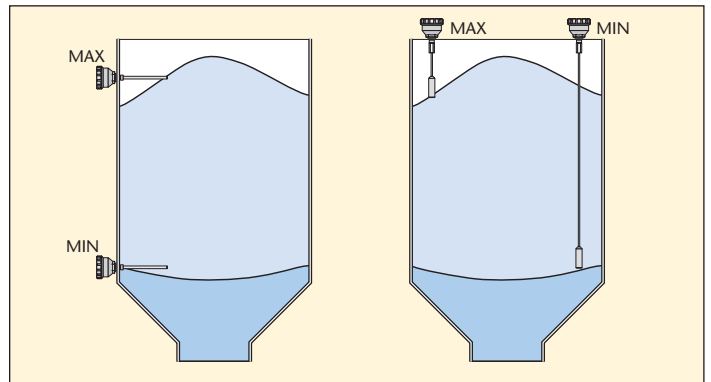

The value of the dielectric constant of the material must not be too low, it must in any case differ significantly from 1, furthermore it is important to bear in mind the composition of the material, humidity content, temperature etc.

SENSITIVITY ADJUSTMENT AND CONNECTION DIAGRAM

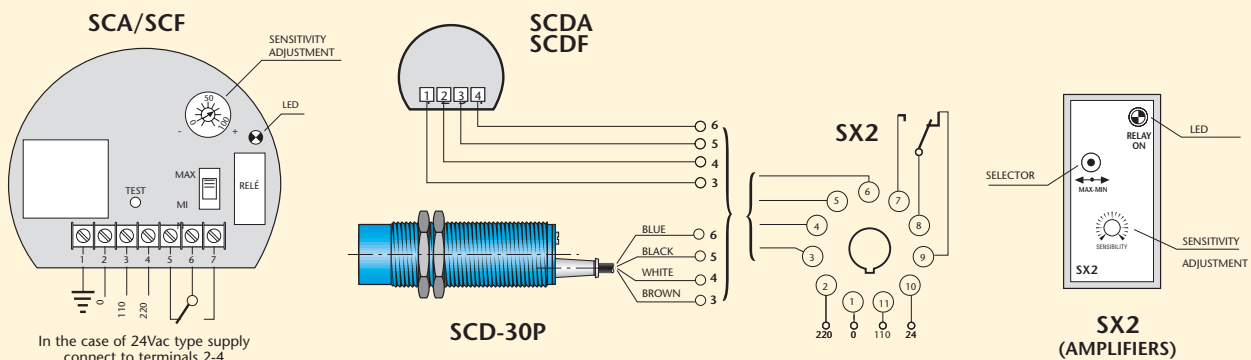

Meyer Industrie-Electronic GmbH - MEYLE

Carl-Bosch-Straße 8
49525 Lengerich/Germany
Internet: www.meyle.de

Tel.: (+49) 0 54 81/93 85-0
Fax: (+49) 0 54 81/93 85-12
E-Mail: sales@meyle.de

CAPACITIVE LEVEL CONTROLS SC - SCD SERIES



SCA - SCF TYPES

This is the compact version which has both the mechanical and electronic parts in one unit.

They are supplied with bar electrodes of teflon coated steel (SCA) with standard lengths of 300 - 500 - 800 mm, or with cable electrodes which are of plastified steel and tensioning, weight covered in teflon (SCF) with standard lengths of 1.000 - 2.000 - 3.000 - 4.000 mm, these are easily shortened.

SCDA - SCDF TYPES

These types have the electronic and mechanical parts separate. The power supply/amplifier is situated in the SX2 unit.

In this version the connection cable between the probe and the control unit can be of any length, it is recommended that this cable be kept separate from any power cables or that it be screened.

The mechanical parts are supplied as per the compact version with bar or cable probes of equal characteristics.

This system is used when it is necessary to have the calibration and the visualisation of operation in one control panel.

SCD30P TYPES

This minituarised version presents itself as a capacitive sensor but it works in conjunction with the SX2 unit. It is used when it is necessary to have the calibration and the visualisation of operation in one control panel and where the small dimensions of the sensing unit over come space problems.

MECHANICAL CHARACTERISTICS OF THE PROBES

The body of the SC and SCD probes is an aluminium casting with two cable clamps on the outputs, standard fixing 1 1/2" GAS, available also 1" or 2" GAS. The body has a degree of protection of IP 65 which allows for outside installation.

The body of the SCD30P is of macrolon plastic and can be used in combination with the SCM protection housing (Page 65)



ELECTRICAL CHARACTERISTICS

Supply voltage $\pm 15\%$	24Vca-110/220Vca 50 \pm 60Hz
On request power supply	24Vcc (Not SX2)
Temperature limits type SC	-20 \pm +60°C
Temperature limits type SCD / SCD-30P	-20 \pm +100°C
Temperature limits type SX2	-20 \pm +60°C
Maximum absorption	2,5VA
Output with 1 pole changeover	5A a 220Vca
Degree of protection type SC / SCD	IP65
Degree of protection type SCD-30P	IP67
Maximum tank pressure	12 Kg./cmq.

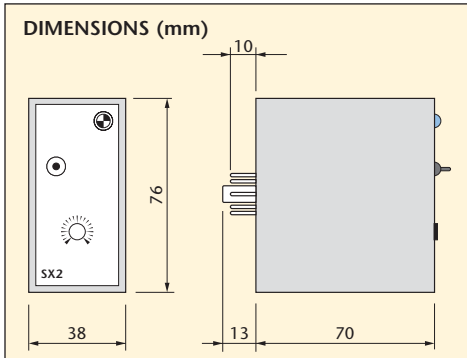

DIMENSIONS (mm)

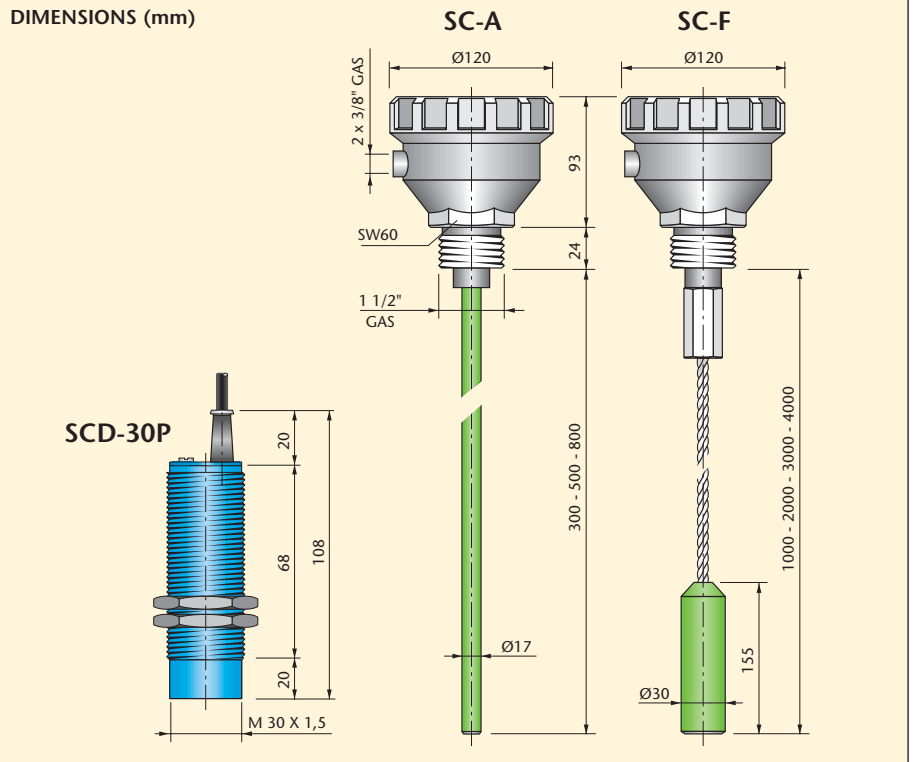

Meyer Industrie-Electronic GmbH - MEYLE

Carl-Bosch-Straße 8
49525 Lengerich/Germany
Internet: www.meyle.de

Tel.: (+49) 05481/9385-0
Fax: (+49) 05481/9385-12
E-Mail: sales@meyle.de