

Type No.

X020.200M



X020.200M

Datalogger

with enhanced configuration software, suitable for WINDOWS® 95/98/NT/2000/XP; compact design with integrated LC-display and memory module for PCMCIA memory cards, suitable for applications in meteorological, hydrological and environmental measuring systems, as well as various other industrial applications.

The datalogger enables the user to enter his individual system configuration in an easy manner, whereby sensors of almost any kind can be integrated (refer to "Configuration").

The essential features at one sight:

- 2 versions of operating frequency: 20 MHz (Standard) or 5 MHz (Low Power).
- 8 analog inputs (16 Bit resolution) and 6 digital I/O ports, as well as additional arithmetical channels, thus featuring a maximum of 32 channels configurable. Connection of any common sensor type. Analog inputs with 2-, 3- or 4-line connection. Wide selection of measuring ranges (e.g. for voltage measurement, from ± 6.25 mV). Connection of thermocouples.
- User-achievable menu-guided configuration under WINDOWS® 95/98/NT/2000/XP.
- Built-in 256 kB RAM, extendable by means of SRAM-Card, max. 6 MB, in PCMCIA-slot. Flash memory cards available from 2 MB to 16 MB.
- Operating temperature range -30...+60°C.
- Compact SMD design. Shell fits on standard rail; plug-in screw terminals for up to 1.5 mm² at the front.
- Wide range of accessories available, such as evaluation software and battery/solar supply.
- Extended ranges for scan rate (0.5 s to 60 min) and averaging interval (1 s to 12 h).
- Averaging interval changeable by process controlled triggering.



X020,
installed in stainless steel housing
type X910 (see group 9)

Due to the dataloggers low power consumption, battery-supplied systems for autonomous operation for about several weeks continuous measuring period can be realized (5 MHz version).

This period may be extended by use of solar panel supply.

Upon request, complete systems (mobile or stationary), incl. all sensors, masts, supports, as well as personal computer and software, GSM- or short range wireless modem incl. antenna, can be quoted.

Several standard software programs for data transfer and data evaluation are available.

Individual custom software can be realized also upon request.



X021.200M

LT Data logger

Type No.
X021.200M

Datalogger LT 1021 is a simplified version of the X020.200M without display and multi function switch, still suitable for a large number of applications mentioned before. Further equipped with some additional features, for example: Baud rate up to 115,200 bps, 1 analog output 0...10 V and a housing version with IP 65 aluminium shell, for outdoor operation. Further details, refer to "Technical Data".



X021.20M2

Data logger

X021.20M2

Aluminium housing, IP 65 with 10 cable ducts. The plug-in screw terminals are accessible after opening the lid.

Technical Data

X020

Inputs: Defined by software
analog: 8 x, for current-, voltage- and resistance measurement; 16 bit analog/digital conversion, 2-,3- or 4-line connection; resp. single-ended or differential;
 resolution: 0.003...0.03 %, range dependant
 accuracy: 0.01...0.3 %; range dependant *
 linearity: 0.01 %;
 temp. drift: 25 ppm/K; 2 ppm/K with drift correction *
 ranges: $\pm 6.25 \text{ mV} \dots \pm 10 \text{ V}$; $62.5 \mu\text{A} \dots 25 \text{ mA}$; $200 \Omega \dots 20 \text{ k}\Omega$
digital: 6 x I/O port, for frequency measurement, counter, status and special Gray Code;
 as input: max. 18 V DC resp. max. 2 kHz;
 as output: Open Collector, max. 18 V DC resp. max. 100 mA
Interfaces: 1 x RS232, 1 x RS485; each ASCII- or PROFIBUS compatible, baud rate max. 38,400 bps
Analog output: none
Data storage: PCMCIA Flash Memory Card up to 10 MB; resp. 256 kB internal RAM, extendable up to 32 MB
Display: LCD, 2 x 16 characters, contrast adjustable,
Power supply: 10...18 V DC; upon configuration, from 70 mW
Operating temperature: -30...+60°C; storage: -30...+85°C
Construction: Aluminium/ABS housing for installation on standard rail 35 mm, acc. to EN 50022; connection with plug-in terminals for up to 1.5 mm²
Dimensions: 189 x 90 x 83 mm (W x H x D)
Weight: approx. 720 g

X021

Inputs: Defined by software
analog: 6 x, for current-, voltage- and resistance measurement; 10 bit analog/digital conversion, 2- or 4-line connection; single-ended
 resolution: 0.1 %
 accuracy: < 0.2 %
 linearity: < 0.1 %
 temp. drift: 25 ppm/K;
 ranges: $\pm 50 \text{ mV}$, 0... 1 V; 0...10 V; current measurement with ext. shunt, 0...2 k Ω
digital: 16 x I/O port for status, 6 of these channels also for counter, frequency measurement or special Gray Code;
 as input: max. 30 V DC resp. max. 2 kHz
 as output: Open Collector; max. 30 V DC resp. max. 100 mA
Interfaces: 1 x RS232, 1 x RS485; ASCII, PROFIBUS or MODBUS RTU, baudrate max. 115,200 bps
Analog output: 1 x 0...10 V, 40 mV resolution
Data storage: Internal RAM 512 kB
Display: None
Power supply: 10...30 V DC; upon configuration approx. 1 W
Operating temperature: -30...+60°C; storage: -30...+85°C
Construction: Aluminium/ABS housing for installation on standard rail 35 mm, acc. to EN 50022; connection with plug-in terminals for up to 1.5 mm². Optional IP 65 aluminium shell.
Dimensions: 189 x 90 x 83 mm (W x H x D), IP65-housing version: 220 x 120 x 80 mm
Weight: approx. 575 g

*) Accuracy can further be enhanced by drift correction, e.g. for temperature measurement by means of Pt 100 typically $\pm 0.03^\circ\text{C}$, voltage measurement typically $\pm 3 \mu\text{V}$

Configuration

Configuring the datalogger, as well as the datalogger V. LT, is accomplished by means of a WINDOWS® 95/98/NT/2000/XP based PC-software. Hereby the channel layout for all inputs is supported by a data base, comprising data of all common sensors. Configuration and connection is displayed and stored and printed out, if required. Next to analog and digital inputs, mathematical adaptations as well as control- and alarm functions may be realized. Further, virtual variables (arithmetic channels) can be added, up to 32 channels totally. By means of this feature, linearization, arithmetic operations like summation and subtraction, maxima, minima, standard deviation etc. can be accomplished. The configuration carried out on a PC is directly transmitted to the datalogger via RS232 resp. RS485 interface, and is similarly accessible in reverse direction. Measuring values of all channels can equally be displayed. For use with different applications, a number of configurations can easily be created and entered to the datalogger correspondingly, by means of a few mouseclicks.

Example for configuration: Measuring system for waste treatment plant

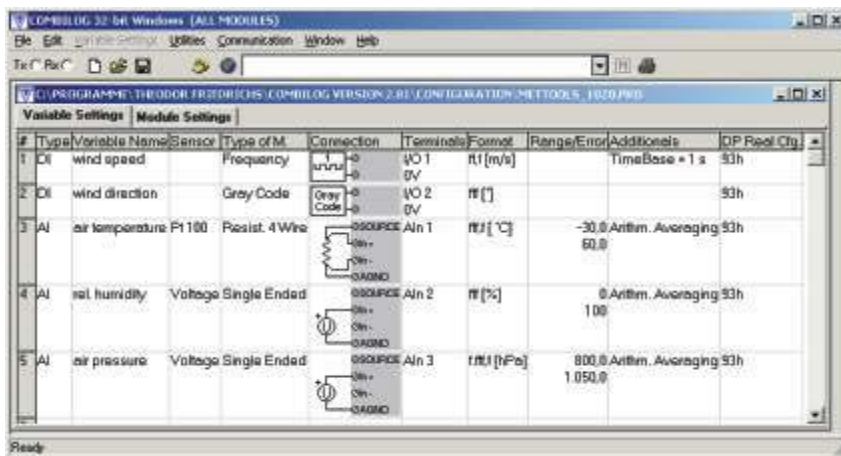

Thanks to its WINDOWS® based menu, the configuration table can easily be created or changed by the user. Each field within the matrix can be activated by mouseclick, thus opening a window, showing all options available. Further mouseclick will activate the chosen option. The complete matrix can be printed as a screen hardcopy and can be used as a hardware connection plan, as well.

Accessories and peripheral modules:

Digital connection board, to connect up 8 parallel status signals to a digital datalogger input

X025.000M

GSM-Modem

X026.000M

Antenna rod 4 dB, incl. duct for housing installation and set of cables (for supply, data and antenna connection)

X026.100M

Additional accessories as Telephone Modem etc. upon request



GSM-Modem

PCMCIA Flash Memory Card, 2 MB

X035.400M

PCMCIA Flash Memory Card, 10 MB

X035.500M

RAM-extension PCMCIA SRAM Card, 2 MB

X036.100M

RAM-extension PCMCIA SRAM Card, 6 MB

X036.200M

Reader unit for PCMCIA Flash cards, PC built-in version

X039.000M

Operating software to read out PCMCIA Flash Memory Cards, suitable for WINDOWS® NT

X039.100M

Operating software to read out PCMCIA Flash Memory Cards, suitable for WINDOWS® 2000

X039.200M

and WINDOWS® XP

Type No.

Display Software datalogger 32

X029.20M1

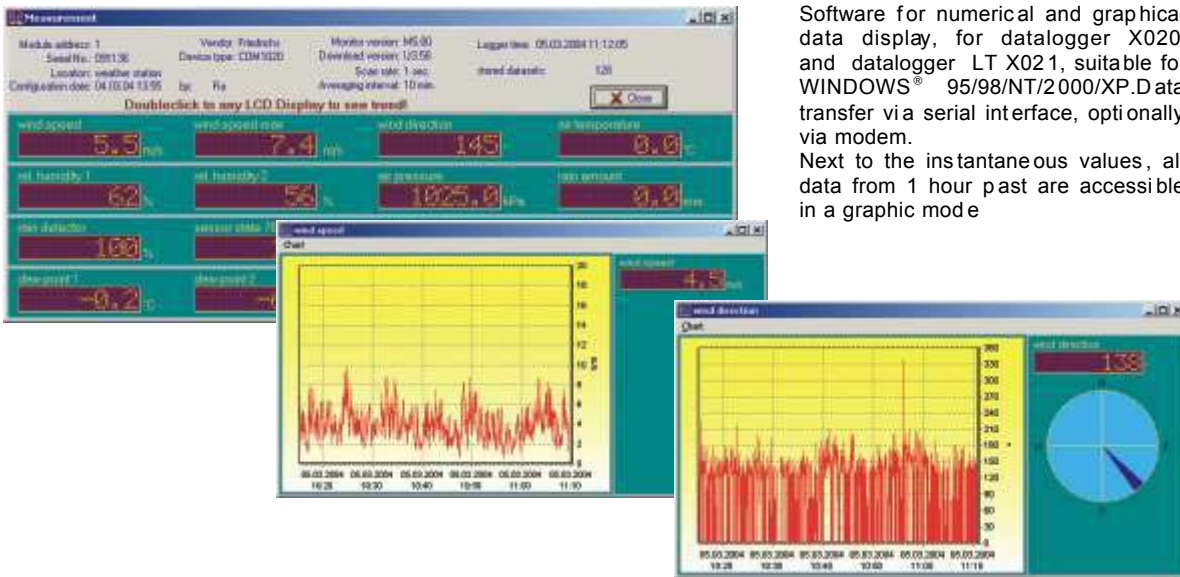

Software for numerical and graphical data display, for datalogger X020 and datalogger LT X021, suitable for WINDOWS® 95/98/NT/2000/XP. Data transfer via serial interface, optionally via modem.

Next to the instantaneous values, all data from 1 hour past are accessible in a graphic mode

Data transfer and evaluation software datalogger 32

X029.30M1

This WINDOWS® 95/98/NT/2000/XP based program enables transfer of all data, stored in a datalogger or datalogger LT. Depending on the datalogger's configuration, the data are either transferred via the serial interface to a PC or stored in the memory card. The card has to be taken out and read by a suitable PCMCIA drive.

The program supports management of several dataloggers, creating an individual table of data storage for each logger. Data storage is accomplished within a data base; export of data to ASCII code is possible, thus featuring further data processing by common programs, such as MS EXCEL®. The processed data are displayed as numerical or graphical schemes and can be printed out, upon requirement.

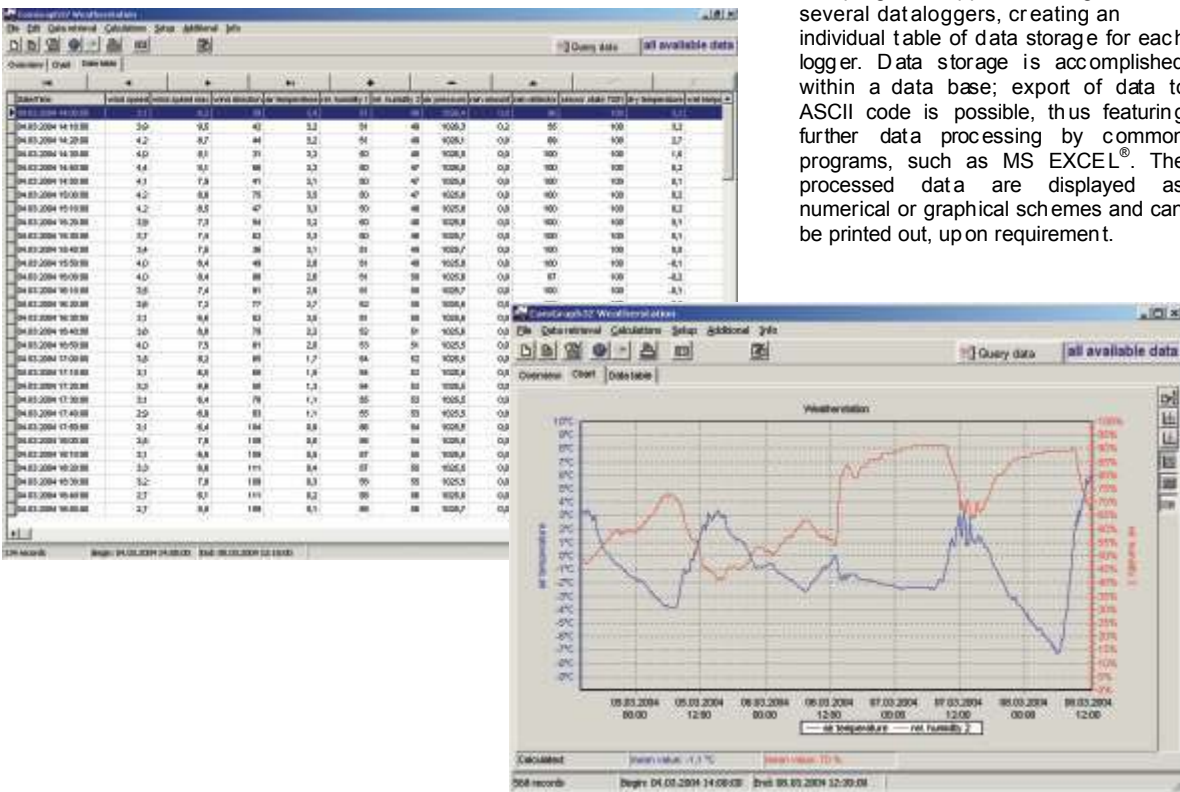

Type No.

X031.000M

AVIATION - Software for Airport Systems

for data acquisition and - processing meteorological measuring data suitable for WINDOWS® 95/98/NT/2000/XP. All relevant parameters for aviation can be processed, converted to METAR or SPECI codes and transmitted as message.

Preferable the data acquisition is performed by means of datalogger X020 respectively X021. Visibility- and cloud height sensors are connected to the PC via the serial interfaces directly. The messages in METAR or SPECI Code are available via serial interface or modem, depending on the selected time interval.

Next to the shown numerical indication all measuring data are also displayed as a graph basing on 3 hours. All relevant airport data as ICAO-Locator, run way direction, altitude etc. is entered by a "Set-Up" mode.

Custom made layout upon request



Measuring Converter for analog signal processing

X024.000M

Data acquisition: 4 analog, 3 digital inputs
 Data output: 4 analog, 1 digital output, connection for 3 – coil receiver (selsyn motor or system), 3 serial interfaces
 Power supply: 24 VDC, isolated

Construction: Euro card contained in Aluminium housing
 Dimensions: 165 x 105 x 30 mm
 Weight: ca. 350 g

Custom Specific Configuration

X024.100M

of the measuring converter for analog signal processing

Configuration- and Evaluation Software for precipitation datalogger

X032.000M

(refer to group 7, type X041)

RS232 Interface Cable for data read-out

X032.100M

(refer to group 7, type X041)

Type No.

Universal Measuring Converter

X110.000M

for analog signal processing

Data acquisition: 1 analog and 1 digital Input,
for alternative connection of sensors
for wind speed, wind direction,
temperature, rel. humidity, air pressure,
solar radiation as well as precipitation

Data output: 2 analog outputs for instantaneous and
average value 0/4 ...20 mA

Accuracy: $\pm 0.1\%$ basing on FS

Power supply: 10...30 VDC, isolated

All setups by software.

Size: Euro card incl. Connector
Dimensions: 168 x 100 x 35 mm
Weight: approx. 50 g

Radiation Measuring Converter

X130.0000M



Input: -8...+24 mV or 0...32 mV (selectable)
Output: 4...20 mA
(simultaneously for supply)

Operating temp.: -40°C ...+80°C

Housing: Aluminium, 64 x 58 x 34 mm, IP 65

Intelligent Sensor Module, IMS 111

X040.100M



Multi-channel module with 4 analog inputs suitable for measuring current, voltage and resistance (also for thermocouples, PT 100 resistance, bridge inputs etc.). Additional 4 digital inputs / outputs available for signal monitoring, resp. controlling tasks. After measurement (up to 16 Bit resolution), linearisation and scaling the individual signal is transmitted via an RS 485 fieldbus interface. Local intelligence enables the IMS 111 to perform complex mathematical and logic functions using both measured inputs and internally calculated variables. The IMS 111 supports industrial standard protocols Profibus-DP, Modbus-RTU and ASCII (special). The module is suitable for standard rail mounting.

Intelligent Sensor Module, IMS 112

X040.200M



Multi-channel module with 4 analog inputs suitable for measuring current, voltage and resistance (also for thermocouples, PT 100 resistance, bridge inputs etc.). Additional 2 digital inputs / outputs available for signal monitoring, resp. controlling tasks. After measurement (up to 16 Bit resolution), linearisation and scaling the individual signal is transmitted via an RS 485 fieldbus interface. Local intelligence enables the IMS 112 to perform complex mathematical and logic functions using both measured inputs and internally calculated variables. Further, the IMS 112 is equipped with an analog current output, also usable as PID controller. The IMS 112 supports industrial standard protocols Profibus-DP, Modbus-RTU and ASCII (special). The module is suitable for standard rail mounting.

Intelligent Interface-Converter, IKS 100

X041.000M



Universal desk top RS-232 / RS-485 Interface-Converter with automatic baudrate-detection. Galvanic isolation protects connected devices from transients up to 1.5 kV. An 18 W power supply for additional up to 6 IMS series modules is built-in.

Type No.

Intelligent Interface-Converter, IKS 101

X041.100M



Universal RS 232 / RS 485 Interface-Converter, integrated in a standard DB09 case. The IKS 101 covers an automatic baud rate selection as well as selection of signal direction. Built-in LED's indicate the actual status. Supply is achieved via the fieldbus.

Intelligent Repeater / Converter, IKR 100

X041.200M



Universal RS 485 Repeater/Converter separates a RS 485 Bus from a second one and extends the RS 485 fieldbus by additional max. 31 modules. Totally 3 repeaters can be cascaded, enabling cable length up to 4.8 km. Isolation from each other and from the network structure enables simple installation and enhances the network's immunity from noise. The converter IKR 100 enables the conversion of signals from RS 232 into RS 485 and reverse. Galvanic isolation protects the connected computer against transients up to 1.5 kV. The IKR 100 is suitable for standard rail mounting.

Cold Junction Compensation, 4-pole, IJC 104

X045.000M

for connecting thermocouples with a datalogger

Bus Connector, IMC 100

X045.100M

for connecting – power supply and fieldbus – of all series 100 modules and datalogger COMBILOG / COMBILOG LT

Bus Terminator, ITB 100

X045.200M

for correct termination of RS 485 fieldbus

blox A1-1

X050.0000M



blox is a modular measuring system for complex applications in meteorology and hydrology. Most outstanding features are: Extremely high resolution (19 bit at 1 kHz), wide range of signal/sensor connections. Standardized interfaces allow construction of networks with more than 120 modules. Combination with data concentrator e.gate 01 easily enables complete systems with Ethernet-, FTP- resp. Web-functionality. Suitable for 35 mm EN 50022 standard rail mounting.

blox A 1-4

X050.100M

with 4 multifunctional analog inputs and 4 digital outputs, incl. RS485 fieldbus interface.

blox A1-8

X050.200M

with 8 multifunctional analog inputs and 8 digital outputs, incl. RS485 fieldbus interface.

blox D1-1

X051.000M

with 8 digital inputs for status detection or 4 digital inputs for fast count- or frequency measurement, incl. RS485 fieldbus interface.

blox D1-4

X051.100M

with 32 digital inputs for status detection or 16 digital inputs for fast count- or frequency measurement, incl. RS485 fieldbus interface.

Software for graphic evaluation upon request !

Intelligent Data-Concentrator, gate 01

X052.000M

with PROFIBUS-DP and ETHERNET-TCP/IP interface, for connection of automation systems, incl. 4 x RS485 and RS232 for slave devices. Incl. FTP- and Web-Server Function.

Cold Junction Compensation, CCJ-A1

X055.000M

10 pole terminal for connecting thermocouples with blox A1-1 and A4.

Type No.



Indication Instruments

for panel mounting, in different housing dimensions and scale divisions.

Further technical data on request!

| | | |
|-----------------------|----------------------|------------------|
| Indication instrument | , 144 x 144 mm, 90° | X201.000M |
| dto. | , 144 x 144 mm, 240° | X202.000M |
| dto. | , 96 x 96 mm, 90° | X211.000M |
| dto. | , 96 x 96 mm, 240° | X212.000M |

Power Supply

for supply of dataloggers and active sensors, e.g. wind direction sensors

| | | | |
|---------|---|-----------------|------------------|
| Input: | 85...264 V AC, 50...400 Hz | Power supply | |
| Output: | 2 x 12 V DC, 1.2 A, regulated overload protected | DIN rail module | X725.000M |
| | | Housing version | X725.00M2 |

DIN rail module
Dimensions: 113 x 70 x 35 mm
Housing version; polycarbonate housing, grey
Protection class: IP 65
Dimensions: 122 x 160 x 90 mm
Weight: approx. 800 g



Power Supply

for supply of active sensors, e.g. temp./rel. humidity sensors

| | | | |
|---------|--|-----------------|------------------|
| Input: | 86...264 V AC, 50...400 Hz | Power supply | |
| Output: | 1 x 12 V DC, 1.3 A, regulated 1 x 24 V DC, 0.6 A, regulated overload protected | DIN rail module | X726.000M |
| | | Housing version | X726.00M2 |

DIN rail module
Dimensions: 113 x 70 x 35 mm each
Housing version; polycarbonate housing, grey
Protection class: IP 65
Dimensions: 122 x 160 x 90 mm
Weight: approx. 1.2 kg

Power Supply

in AI-housing for the supply of high power wind sensor heaters, wind sensors, types X035 and X123

| | | | |
|-----------------|--|--|------------------|
| Input: | 115/230 V AC, selectable | | X728.000M |
| Output: | 24 V DC / 6.0 A, regulated overload protected | | |
| DIN rail module | | | |
| Dimensions: | 157 x 115 x 87 mm | | |
| Weight: | approx. 0.8 kg | | |

Power Supply

in polycarbonate housing, for supply of precipitation pulse transmitter type X051.10M, or other devices with similar power requirement

| | | | |
|-------------------|--|--|------------------|
| Input: | 230 V, 50 Hz | | X731.000M |
| Output: | 24 V AC, power: 160 VA | | |
| Protection class: | IP 65 | | |
| Dimensions: | 160 x 120 x 140 mm; Weight: approx. 3.4 kg | | |

Power Supply

similar to type X731, for precipitation pulse transmitter type X041.100M and X041.300M.

| | | | |
|-------------------|--|--|------------------|
| Input: | 230 V, 50 Hz | | X732.000M |
| Output: | 24 V AC, power: 63 VA | | |
| Protection class: | IP 65 | | |
| Dimensions: | 122 x 120 x 105 mm; Weight: approx. 1.5 kg | | |

Battery Charger

for 12V-Batteries

| | | | |
|---------|---|--|------------------|
| Input: | 230 V AC, 50 Hz | | X750.000M |
| Output: | 12 V DC, 1.0 A IV ₀ V-characteristic | | |

Type No.



Electrically Aspirated Thermometer

for precise measurement of air temperature; double radiation screen against global- and reflected radiation. Radiation protective tubes chrome plated and heat insulated against each other and against thermometer holder by plastic rings. Ventilation unit for continuous flow speed at sensor approx. 3.5 m/s. Housing material: Anodized aluminium, with additional protective coating.

| | | | |
|------------------|--|---|---------------------------------|
| Sensor: | Platinum resistance thermometer Pt 100, DIN 60751 B 1/3 tolerance (± 0.1 K at 0°C) | 24 V AC Version 12 V DC Version | X010.100M 200M |
| Measuring cable: | 4 x 0.5 mm ² , screened, 5 m length | 230 V AC Version | 300M |
| Power supply: | 24 V AC, approx. 110 mA resp. 12 V DC, approx. 40 mA resp. 230 V AC, approx. 160 mA resp. 24 V DC, approx. 100 mA | 24 V DC Version | 400M |
| Power plug: | Plastic, 7 pin, sealed to IP 67 | Sensor w. guaranteed characteristic within -20...+40°C with plug connection | 100M 1M |
| Fastening: | Cross arm with clamp | | |
| Dimensions: | max. \varnothing 173 mm, height 470 mm | | X010. |
| Weight: | approx. 2.4 kg | | |

Electrically Aspirated Thermometer with Twin Sensor
as type X010, but with two parallel thermometers

X012.000M

Air Temperature Sensor 5 cm above Soil

X014.000M



with protective housing against weather and radiation influences. Housing material: Anodized aluminium, with additional protective coating.

| | |
|------------------|--|
| Sensor: | Platinum resistance thermometer Pt 100, DIN 60751 B, 1/3 tolerance |
| Measuring cable: | 4 x 0.5 mm ² , screened, 5 m length |
| Dimensions: | 335 x 75 x 90 mm |
| Weight: | approx. 0.95 kg |

Heat Flux Plate

for measuring heat flux in walls or in soil, e.g. for building structure research or agrometeorological application. Also available as selv-calibrating version.



| | | | |
|-----------------------|---|--------------------------|-------------------|
| Sensitivity: | 50 μ V / Wm ⁻² | Basic version | X016.000M |
| Resistance (nominal): | 2 Ω | | |
| Operating temp.: | -30...+70°C | Selv-calibrating version | X016.1000M |
| Meas. range: | ± 2000 Wm ⁻² | | |
| Response time: | ± 4 min | | |
| Accuracy, typical: | ± 3 % | | |
| Dimensions: | \varnothing 80 x 5 mm, cable length 5 m | | |
| Weight: | approx. 0.3 kg | | |

Temperature Sensor for Soil Temperature resp. Water Temperature

X018.000M



in stainless steel shaft 1.4571, with waterproof sealing.

| | |
|-------------|--|
| Sensor: | Platinum resistance thermometer Pt 100, DIN 60751 B, 1/3 tolerance |
| Connection: | Measuring cable 4 x 0.5 mm ² , screened, 5 m, with PTFE/silicon coating |
| Dimensions: | \varnothing 8 mm, length approx. 100 mm; weight: approx. 0.35 kg |

Temperature Sensor for Room Temperature

X019.000M

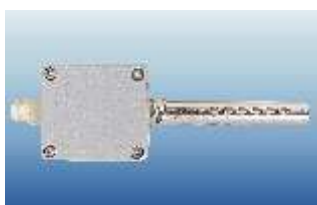

on cable box with perforated protective tube, suitable for indoor and outdoor measurement.

| | |
|-------------|--|
| Sensor: | Platinum resistance thermometer Pt 100, DIN 60751 B, 1/3 tolerance |
| Dimensions: | 170 x 60 x 40 mm (H x W x D); |
| Weight: | approx. 0.2 kg |

Meyer Industrie-Electronic GmbH – MEYLE

Type No.



Water Temperature Sensor for Ship Installation

X020.000M

to screw into a plunger type X021. Material: Stainless steel 1.4571

Sensor: Platinum resistance thermometer Pt 100, DIN 60751 B, 1/3 tolerance
Dimensions: 240 x 72 mm; weight: approx. 0.45 kg

Weld-in Plunger for Water Temperature Sensor

X021.000M

to be welded into water chambers on board of ships, on oil rigs or similar.
Material: Stainless steel 1.4571



Air Temperature Sensor in shelter

in different versions with electrical ventilation and integrated measuring converter. The shelter consists of 12 white lamellae. Its aerodynamically optimised design features a most efficient horizontal air flow. The electrical ventilated version avoids short circuit of flow by means of its special guiding tube.

| | | | |
|----------------------|--|--|-------------------|
| Dimensions: | approx. Ø 120 mm x 240 mm | Air temperature sensor in shelter | X030.000MT |
| Weight: | approx. 1.4 kg | | |
| Sensor: | Platinum resistance thermometer Pt 100, DIN 60751B, 1/3 tolerance | Air temperature sensor in shelter, | |
| Connection cable: | (Versions 2030.0000 and .1000 only): LiY (C)Y, 4 x 0.5 mm ² , 5 m length (Fan: LiYY, 2 x 0.25 mm ² , 5 m length) | electrically aspirated | X030.100MT |
| Fan: | 12 V DC, approx. 70 mA (Versions 2030.1000 and .1100 and .1200 only) | Air temperature sensor, incl. measuring converter 0...20 mA in shelter | X030.010MT |
| Measuring converter: | | Air temperature sensor, incl. measuring converter 4...20 mA in shelter | X030.020MT |
| Input: | Pt 100, meas. range -35...+45°C | | |
| Output: | 0...20 mA; supply 12...24 V DC, load depending (25...850 Ω lin.) 4...20 mA; supply 12...24 V DC, load depending (500 Ω...1.9 kΩ lin.) | Air temperature sensor, incl. measuring converter 0...20 mA in shelter, electrically aspirated | X030.110MT |
| Max. error: | ± 0.25 % | | |
| Error by: | Supply voltage: < 50 ppm/V Ambient temp.: < 50 ppm/°C | Air temperature sensor, incl. measuring converter 4...20 mA in shelter, electrically aspirated | X030.120MT |
| EMV, Emission: | EN 50081-1 | | |
| EMV, Noise: | EN 50082-2 | | |
| Operating temp.: | -40...+60°C | | |
| Connection: | 6-pole Connector IP 67 | | |

Thermograph



with U-shaped double bimetallic strip as measuring element, white coloured case with acrylic sheet cover; clockwork mechanism adjustable for weekly or daily rotation. For applications down to -35°C, optionally with quartzdrive

| | | |
|-------------|--|------------------|
| Ranges: | -35...+45°C | X210.100M |
| | -15...+65°C | X210.200M |
| Accuracy: | ±0.5°C in the centre of ranges (-10...+30°C resp. -10...+50°C) ±0.8°C in the ends of ranges | |
| Dimensions: | 290 x 145 x 190 mm; weight: approx. 1.9 kg | |

Outboard Thermometer (Navy Bucket)



in carrying case, to measure water temperature and take water samples; with accessories and spare parts.

| | |
|--|--|
| Bucket compl. with carrying case and accessories | X510.000M |
| Bucket with thermometer and rope, but without case and accessories | X511.000M |
| Meas. range: | -10...+40°C |
| Scale division: | 0.5°C |
| Dimensions: | |
| Bucket: | max. Ø 135 mm, height 385 mm; weight: approx. 4.6 kg |
| Case: | 335 x 235 x 435 mm; weight: approx. 6.2 kg |

Hg – Thermometers



X510

X520

X530

Type No.

Thermometer for Navy Bucket

X510.0000.M1

Meas. range: -10...+40°C
Scaling: 0.5°C
Dimensions: 240 mm length

Air-Thermometer

X520.000M

with double radiation screen, in chrome plated brass housing

Meas. range: -35°C...+60°C
Scaling: 1°C
Dimensions: max. Ø 105 mm, height 410 mm
Weight: 0.45 kg

Thermometer in protective housing (Cold Store House Thermometer), compl.

X530.000M

incl. manufacturer's certificate
Meas. range: -10...+15°C
Scaling: 0.1°C
Dimension: 365 mm length

Thermometer, separate
Housing, separate

X530.0000.M1
X530.0000.M2

Soil Thermometer in acc. DIN 58655

| Meas. range | Scaling | Soil depth | |
|--|---------|------------|------------------|
| -25...+60°C | 0.2°C | 0 cm | X540.100M |
| dto., incl. manufacturer's certificate | | | X540.10M1 |
| -25...+60°C | 0.2°C | 2 cm | X540.200M |
| dto., incl. manufacturer's certificate | | | X540.20M1 |
| -25...+45°C | 0.2°C | 5 cm | X540.300M |
| dto., incl. manufacturer's certificate | | | X540.30M1 |
| -20...+40°C | 0.2°C | 10 cm | X540.400M |
| dto., incl. manufacturer's certificate | | | X540.40M1 |
| -15...+35°C | 0.2°C | 20 cm | X540.500M |
| dto., incl. manufacturer's certificate | | | X540.50M1 |
| -15...+35°C | 0.2°C | 30 cm | X540.600M |
| dto., incl. manufacturer's certificate | | | X540.60M1 |

Support f. 1 pce. Soil Thermometer

X541.000M

Soil Depth Thermometer

Meas. range: -10...+30°C
Scaling: 0.1°C, incl. mount. tube
Dimensions: Length 320 mm

for depth 50 cm **X545.100M**
for depth 100 cm **X545.200M**

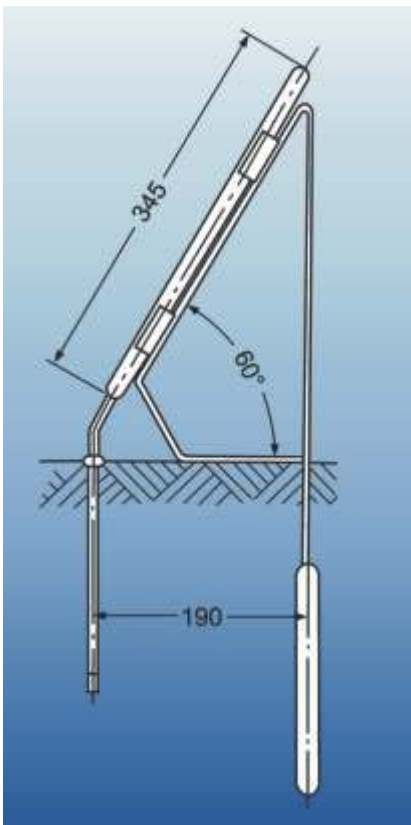

X540 / X541

Type No.

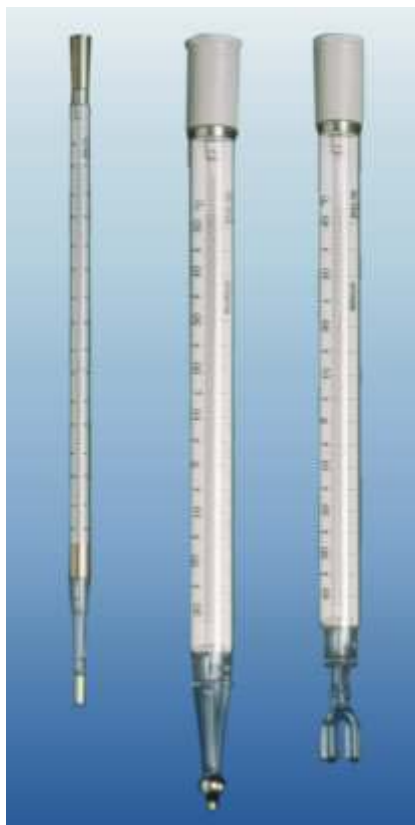

X060.1000.M1 X070.0000.M2 X070.0000.M3

Thermometers for Aspiration Psychrometer

Scaling: 0.2°C
 Dimensions: Length 280 mm
 Meas. range: -10...+60°C
 dto., incl. manufacturer's certificate
 Meas. range: -35...+40°C in acc. DIN 58661
 dto., incl. manufacturer's certificate

X060.1000.M1
X060.1000.M2
X060.2000.M1
X060.2000.M2

Psychrometer-Thermometer for Types X070 and X071

Scaling: 0.2°C
 Dimensions: Length 370 mm
 Meas. range: -35...+40°C in acc. DIN 58660
 dto., incl. manufacturer's certificate

X070.0000.M1
X070.0001.M1

Extreme Thermometers for Type 3070

Scaling: 0.5°C
 Dimensions: Length 290 mm
 Max. thermometer
 Meas. range: -30...+50°C, in acc. DIN 58654
 dto., incl. manufacturer's certificate

X070.0000.M2
X070.0001.M2

Scaling: 0.5°C
 Dimensions: Length 290 mm
 Min. thermometer
 Meas. range: -40...+40°C, in acc. DIN 58653
 dto., incl. manufacturer's certificate

X070.0000.M3
X070.0001.M3

Set (=2 pieces.) Control Thermometer for Test Bath Type X100 / X101,



Scaling: 0.1°C
 Dimensions: Length: 460 mm
 max. Ø = 14,5 mm
 incl. manufacturer's calibration certificate
 dto., with official calibration certificate

X117.00M1
X117.00M2

Meas. range: -38...+10°C, separately
 incl. manufacturer's calibration certificate
 dto., with official calibration certificate

X117.0001.M1
X117.0002.M1

Meas. range: -1...+51°C, separately
 with manufacturer's calibration certificate
 dto., with official calibration certificate

X117.0001.M2
X117.0002.M2

X117.000M



Electrically Aspirated Psychrometer

to measure the dry and wet bulb air temperature with highest precision. From these two temperatures the relative humidity, the dewpoint and other humidity data can be calculated. The design is similar to type X010, but equipped with two resistance thermometers, whereas one of the thermometers - covered by a moisturing wick - is continuously moistened from a screwed-in 200 ml water container. The direction of moistening flow is against the airstream, which has an approximate flow speed of 3.0 m/s.

| | | | | |
|-------------------|---|--|------------------|-------------|
| Housing material: | Anodized aluminium, with additional protective coating | 24 V AC version | X010.100M | |
| Sensors: | Platinum resistance thermometers Pt 100, DIN 60751 B, 1/3 tolerance (± 0.1 K at 0°C) | 12 V DC version | | 200M |
| Measuring cables: | 4 x 0.5 mm ² , screened, 5 m length | 230 V AC version | | 300M |
| Power supply: | 24 V AC, approx. 110 mA resp. 12 V DC, approx. 40 mA resp. 230 V AC, approx. 160 mA resp. 24 V DC, approx. 100 mA | 24 V DC version | | 400M |
| Power plug: | Plastic, 7 pin, sealed to IP 67 | Sensors with guaranteed characteristic within -20...+40°C with plug connection | | |
| Fastening: | Cross arm with clamp | | | |
| Dimensions: | max. \varnothing 173 mm, height 534 mm | | | |
| Weight: | approx. 3.1 kg | | | |

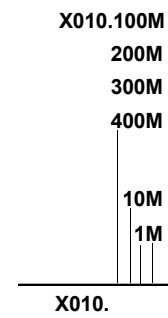

Temperature / Humidity Sensor in Shelter



in different versions with electrical ventilation and integrated measuring converter. The shelter consists of 12 white lamellae. Its aerodynamically optimised design features a most efficient horizontal air flow. The electrical ventilated version avoids short circuit of flow by means of its special guiding tube.

| | | | |
|-----------------------|---|---|--------------------|
| Humidity sensor: | Capacitive probe | Temperature/humidity sensor in shelter | X030.000MHT |
| Measuring range: | 0...100 % rH | | |
| Calibration accuracy: | ± 1.5 % rH | | |
| Long term stability: | 1 % rH / year | | |
| Time constant: | 0.7 s | Temperature/humidity sensor in shelter, electrically aspirated | X030.100MHT |
| Output: | 0...1V corresponding 0...100% rH | | |
| Impedance: | > 10 k Ω | | X030.01MHT |
| Temp. Sensor: | Pt 100, DIN 60751 B, 1/3 tolerance | Temperature/humidity sensor, incl. measuring converter 0...20 mA in shelter | |
| Output: | Resistance Pt 100, 4-line | | X030.020MHT |
| Supply: | 3.5...50 V DC | | |
| Operating temp.: | -40...+60°C | Temperature/humidity sensor, incl. measuring converter 4...20 mA in shelter | X030.110MHT |
| Dimensions: | \varnothing 120 mm x 240 mm | | |
| Weight: | max. 1.4 kg | Temperature/humidity sensor, incl. measuring converter 0...20 mA in shelter, electrically aspirated | X030.120MHT |
| Connection cable: | (Versions 3030.0000 and .1000 only) LiY(C)Y, 8 x 0.25 mm ² , 5 m length) | | |
| Fan: | 12 V DC, approx. 70 mA (Versions 3030.1000 and .1200 only) | | |
| Measuring converter: | | | |
| Input: | Voltage. 0...1.0 V; meas. range: 0...100% | Temperature/humidity sensor, incl. measuring converter 4...20 mA in shelter, electrically aspirated | X030.120MHT |
| Output: | Pt 100, meas. range -35...+45°C 0...20 mA; supply 12...24 V DC, load depending (25...850 Ω lin.), 4...20 mA; supply 12...24 V DC, load depending (500 Ω ...1.9 k Ω lin.), | | |
| Max. error: | ± 0.25 % | | |
| Error by: | Supply voltage: < 50 ppm/V Ambient temp.: < 50 ppm/°C | | |
| EMV, Emission: | EN 50081-1 | | |
| EMV, Noise: | EN 50082-2 | | |
| Operating temp.: | -40... +40°C | | |
| Connection: | 6-pole connector IP67 | | |

Type No.



Aspiration Psychrometer

Instrument for determination of relative humidity and dew point; with clockwork driven fan for ventilating both thermometer bulbs. Delivered in a wooden carrying case.

Meas. range: -10...+60°C
 -35...+40°C (in acc. DIN 58661)
Other ranges upon request!
 Scaling: 0.2°C
 Dimensions: max. Ø 100 mm, length 440 mm
 Weight: approx. 1.5 kg

X060.100M
X060.200M



Psychrometer

to measure the temperature and the temperature extremes, and to determine rel. humidity; electrically driven aspirator with battery (rechargeable by charger unit) to ventilate both thermometers; consisting of: Stand, thermometer support, aspirator type X072, psychrometer thermometers, maximum- and minimum-thermometer.

Meas. range: -35...+45°C (in acc. DIN 58660)
Other ranges upon request!
 Scaling: Psychrometer thermometer 0.2°C
 Max./min. thermometer 0.5°C
 Dimensions: Height 600 mm
 Weight: approx. 2.3 kg

X70.000M

Psychrometer

As above, but without max./min. thermometer

X071.000M



Battery-operated

with rechargeable battery and power set with standard connection.

Power supply for charger: 230 VAC, 50 Hz (Plug-in power supply)
 Dimensions of aspirator: Ø 50 mm, length 130 mm
 Weight of aspirator: approx. 0.2 kg

X072.000M



Humidity Sensor

to measure the rel. humidity by means of a special prepared hairstring element, with direct indication of rel. humidity and electrical transmission.

Measuring range: approx. 5...100 %
 Accuracy: ±2.5 %
 Scaling: 1 % rel. humidity
 Operating temperature: -60...+70°C
 Output: Standard value: 0...100 Ω, linearized,
 corresp. 0...100 % rel. humidity
 Weight: approx. 1.5 kg
 Fastening: Thread G 1 with hexagonal nut
 For outdoor operation, a shelter type X120 is recommended

X112.000M

Humidity Sensor

as type X112.000M, but with additional built-in thermometer Pt 100, DIN 60751 B, 1/3 tolerance, for temperature measuring.

X112.100M

Type No.



Shelter for Humidity Sensor

X120.000M

to protect humidity sensor type X112, for installation under outdoor conditions, against weather and radiation influence, internal surface blackened.

- Material: Anodized aluminium, cover with additional coating
- Fastening pin: Ø 22 mm, 28 mm length
- Dimensions: approx. Ø 180 mm, height 440 mm
- Weight: approx. 1.6 kg



Thermohygrograph

with U-shaped bimetallic strip for temperature measurement and hair element for humidity measurement; hair string specially prepared, achieving short setting-up time and wide temperature range. White coloured case with acrylic cover; clockwork adjustable to one revolution per week or per day. Optionally with quartz drive.

- Measuring range: rel. humidity 0...100 %; temperature -35...+45°C
- rel. humidity 0...100 %; temperature -15...+65°C

X200.100M

X200.200M

- Dimensions: 290 x 145 x 260 mm
- Weight: approx. 2.3 kg
- Accuracy: Temperature:
 - ±0,5°C with average measuring range (-10...+30°C resp. -10...+50°C)
 - ±0,8°C with extreme values
 Humidity:
 - ±3 % rel. humidity



Hygrograph

X210.000M

with hair element for humidity measurement; hair string specially prepared achieving short setting-up time and wide temperature range. White coloured case with acrylic cover; clockwork adjustable to one revolution per week or per day. For applications down to -35°C, optionally with quartz drive.

- Measuring range: 0...100 % rel. humidity
- Dimensions: 290 x 145 x 190 mm
- Weight: approx. 1.9 kg
- Accuracy: ±3 % rel. humidity



Polymeter

X310.000M

to determine rel. humidity, temperature, dew point, saturation pressure, deficit of saturation and absolute humidity. Wall mounting.

- Measuring range: 0...100 % rel. humidity
- 30...+50°C
- Accuracy: ±3 % rel. humidity
- Scaling: 1 % rel. humidity, 1°C
- Operating temperature: -25...+60°C
- Dimensions: Ø 100 x 20 mm; height 270 mm
- Weight: approx. 0.25 kg



Hygrometer

X340.000M

as type type X310, but without thermometer.

- Meas. range: rel. humidity only 0...100 %

Type No.

X503.000M



Tensiometer

to measure soil moisture, calculated from the difference between ambient air pressure and reduced pressure in the soil, caused by water tension. Measured by means of a pressure sensor, semi-permeable ceramic suction head and water-filled head as transducer. External refilling. Built-in temperature sensor to measure soil temperature.

- Suction head: Special ceramic SKA 100-FF
Dimensions: 60 x 24 mm
- Head: Length = 80 mm
- Shaft: Ø 25 mm, length = 300 mm (standard)
other length up to 2 m upon request
- Measuring range: -1000...+850 hPa soil water tension
-30...+70°C soil temperature
- Signal: 0...2 V soil water tension
0...2 V soil temperature
- Supply: 6...20 V DC, approx. 7 mA
- Accuracy: Soil water tension ± 5 hPa
Temperature ± 0.2 K (-10...+10°C)
respect. ± 0.5 K (-30...+70°C)
- Shaft material: Acrylic glass, Ø 25 mm,
suitable for winter operation at frost protected immersion
depth
- Intake f. reference
pressure: via porous cable membran
- Cable length: 5 m (standard);
other lengths up to 20 m upon request
8 pole connector IP 67

X505.200M



Equitensiometer

This instrument is based on a patented method to detect the matric potential in the soil (Matric potential is an expression for the amount of energy which is necessary to extract a certain amount, for example 1 gram, of water out of the soil; its unit is kPa). During equilibrium, the matric potential between neighbouring sections of soil is equal, independent from particle size configuration, humus content, density etc.. The equitensiometer takes advantage of this characteristic by getting a ceramic equilibrium probe with known soil moisture characteristic curve in contact with the soil to be measured. After detection of the probe's water content by means of the TDR-principle, the matric potential is directly determined.

- Dimensions: 40 x 20 mm, length 170 mm
- Weight: approx. 0.6 kg incl. 5 m cable
- Cable length: Standard: 5 m; max. 100 m
- Operating
conditions: Soil with low salinity
< 1 mS/cm, pH 2...8.5,
temperature 0...40°C
(below 0°C: wrong measuring values, but no damage to the
probe)
- Output: 0...700 mV
- Supply: 5...15 V DC, max. 23 mA
meas. interval 10 s
- Application range: Precision soil monitoring for
hydrology and plant physiology, control
of irrigation systems, detection of water stress
- Meas. Range: 0...-1500 kPa
- Accuracy: ± 5 kPa at 0...-100 kPa
< 5% at -100...-1500 kPa



Wind Speed Sensor

for transmission of electrically measured wind speed values. Low-inertia 3-cup assembly as sensing element; shaft made of stainless steel, guided in special covered precision ball bearings; housing made of polycarbonate.

Dimensions: Ø 224 mm, height 327 mm, max. housing-Ø 80 mm
 Weight: approx. 0.9 kg (type X021) resp. 0.5 kg (type X034)
 Fastening: Socket Ø 34 x 40 mm length
 Connection: metal connector, IP 67
 Heating: 12 V / 6 W; controlled by thermostat
 Operating temp.: -35...+80°C
 Max. load: 60 m/s

Sensor with **DC measuring generator** which produces a voltage proportional to the wind speed. Suitable for up to 4 analog instruments, connected in line.

| | | | |
|------------------|---|---|------------------|
| Meas. range: | 0...41 m/s = 0...80 kn | Wind Speed Sensor with DC measuring generator | X021.000M |
| Threshold: | 0.8 m/s | | |
| Response length: | approx. 3 m at v = 5 m/s | | |
| Accuracy: | ±0.3 m/s; at v > 15 m/s 2 % of range | as above, with built-in heating | X021.100M |
| Output: | 0...1 mA at Ri = 4 kΩ | | |

Sensor with **reflecting light barrier and frequency output** 0...600 Hz and built-in heating. Additional **analog outputs optionally** available.

| | | | |
|------------------|--|--|------------------|
| Meas. range: | 0...60 m/s = 0...116.7 kn | Wind Speed Sensor with frequency output | X034.000M |
| Threshold: | 0.3 m/s | | |
| Response length: | < 2.5 m at v = 5 m/s | | |
| Accuracy: | ±0.3 m/s; at v > = 15 m/s 2 % of range | as above, with additional analog outputs | X034.100M |
| Output: | Type X034.000M: 0...600 Hz, Open Collector Type X034.100M: 0...600 Hz, Open Collector as well as analog 0...1 V, 0...20 mA, 4...20 mA | | |
| Power supply: | Type X034.000M: 12...30 V DC, approx. 1 mA Type X034.100M: 12...30 V DC, approx. 50 mA | | |
| Admissible load: | approx. 400 Ω | | |

Wind speed sensor; Heavy Duty Design

with CNC-manufactured metal housing (seawater resistant aluminium alloy Al Mg Si 1, black anodized). Special rugged design with improved dynamic features basing on high precision bearings and optimised balancing. Principle of measurement as type X034.



Dimensions: Ø 224 mm, 275 mm height, max. housing-Ø 80 mm
 Weight: approx. 0.685 kg
 Fastening: Socket Ø 34 x 40 mm length
 Connection: metal connector, IP 67
 Heating: 12 V/6 W; controlled by thermostat;
 high performance heating 24 V/60 W

Operating temp.: -25...+80°C; with high performance heating -40...+80°C
 Max. load: 100 m/s

| | | | |
|------------------|--|---|------------------|
| Meas. range: | 0...70 m/s (0...60 m/s for analogue output) | Sensor for windspeed Frequency output 0...700 Hz, open collector with built-in heating. | X035.000M |
| Threshold: | < 0.3 m/s (standard) 0.21 m/s (sensitive version) | | |
| Response length: | < 2,5 m (standard) 2.0 m (sensitive version) | As type X035.000M, but with additional analogue output 0...20 mA, 4...20 mA and 0...1 V, corresp. 0...60 m/s. | X035.100M |
| Accuracy: | ±0.2 m/s; at v > 15 m/s 2 % f. FS. <i>Individual calibration upon request</i> | | |
| Power supply: | Electronic: 12...30 V DC; approx. 50 mA 4.8...30 V DC, approx. 1.0 mA at 12 V for Typ 4035.0000 Heating: 12 V DC; 1.0 A high performance heating: 24 V DC; 2.7 A | As type X035.000M, but with high performance heating. | X035.010M |
| | | As type X035.100M, but with high performance heating. | X035.110M |
| | | Sensitive version: As mentioned above types, but with additional prefix. | -----M 1 |

Type No.



Wind Speed Sensor, small version

cup anemometer, optionally with Reed switch (frequency output) or DC generator. Compact design, low weight and low cost.

| | | | |
|------------------------------|---|---|------------------|
| Meas. range: | 0...41 m/s | | |
| Max. load: | 60 m/s | | |
| Threshold: | 1.2 m/s (type X091.100M) resp. 1.5 m/s (type X091.200M) | Wind Speed Sensor heated, with Reed switch output | X091.100M |
| Power supply: (X091.100M) | Recommended load: 12 V; 0.1 mA in connection with datalogger | | |
| Heating: | 12 V DC; approx. 2 W | | |
| Output signal: | | | |
| Type X091.100M: | Reed switch, 0...118.9 Hz | Wind Speed Sensor with generator output | X091.200M |
| Type X091.200M: | DC-generator, 0...1 mA at Ri = 500 Ω | | |
| Dimensions: | max. Ø: 100 mm, height 127 mm | | |
| Weight: | approx. 120 g | | |
| Installation: | Side bar with 2 holes Ø 6.5 mm | | |
| Connection: | IP 67 connector | | |
| Operating temp.: | -30...+65°C | | |

Wind Direction Sensors

for transmission of electrically measured wind direction values. The vane turns through the influence of the wind pressure into the corresponding wind direction. Shaft made of stainless steel, guided in special covered precision ball bearings; housing made of polycarbonate.

| | |
|------------------------|--|
| Dimensions: | Height 436 mm, turning radius of vane approx. 350 mm |
| Weight: | approx. 0.9 kg |
| Fastening: | Socket Ø 34 x 40 mm |
| Connection: | IP 67 connector |
| Heating: | 12 V / 6 W; controlled by thermostat |
| Operating temperature: | -35...+80°C |
| Max. load: | 60 m/s |
| Threshold: | 0.2 m/s at 90° initial deflection |
| Damping ratio: | 0.57 at v = 3 m/s and initial deflection = 15° |

Sensor with **ringpotentiometer**, for connection of **recorders, data acquisition systems, dataloggers**, etc.; winding gap 2° pointing to North direction.

| | | | |
|----------------|----------------------|------------------------------------|------------------|
| Meas. range: | 1...359° | Wind Direction Sensor, 1...359° | X121.000M |
| Potentiometer: | 1000 Ω, lin. ± 0.3 % | | |
| Power supply: | 12 V DC, max. 1.5 W | as above, with built-in heating | X121.100M |

Sensor with **digital Gray Code** output and built-in heating. Additional **analog outputs** optionally available.

| | | | |
|------------------|---|---|------------------|
| Meas. range: | 0...360° | Wind direction Sensor, with serial output, 8 bit Gray Code | X122.000M |
| Output: | | | |
| Type X122.000M: | 8 bit Gray Code, TTL, serial 600 Bd | | |
| Type X122.100M: | 8 bit Gray Code, TTL, serial 600 Bd as well as analog 0...20 mA, 4...20 mA and 3 phase signal (selsyn motor system) for analog instruments | as above, with addi- tional analog outputs | X122.100M |
| Power supply: | | | |
| Type X122.000M: | 12...30 V DC, approx. 0.5 mA | | |
| Type X122.100M: | 12...30 V DC, approx. 60 mA | | |
| Admissible load: | approx. 400 Ω | | |

Power Supplies for the wind sensors: Refer to product group 1

Masts, cross arms and further accessories: Refer to product group 9

Type No.



Wind Direction Sensor; heavy duty design

with CNC-manufactured metal housing (seawater resistant aluminium alloy Al Mg Si 1, black anodized). Special rugged design with improved dynamic features basing on high precision bearings and optimised balancing. Principle of measurement as type X122.

| | | | |
|---------------------------|---|--|------------------|
| Dimensions: | 370 mm height, turning radius of vane approx. 350 mm | Sensor for wind direction with serial data output, 8 bit Gray Code, TTL, with built-in heating | X123.000M |
| Weight: | approx. 1.015 kg | | |
| Fastening: | Socket Ø 34 x 40 mm length | | |
| Connection: | metal connector, IP 67 | | |
| Heating: | 12 V / 6 W; controlled by thermostat; high performance heating | Sensor for wind direction with serial data output, 8 bit Gray Code, TTL, Analog output | |
| Operating temp.: | 24 V/ 60 W | 0...20 mA, 4...20 mA sincl. 3-phase signal; suitable for analog instruments with built-in heating. | X123.100M |
| | -25...+80°C; with high performance heating - 40...+80°C | | |
| Max. load: | 100 m/s | | |
| Threshold: | 0.2 m/s at 90° | | |
| | Initial deflection | | |
| Damping ratio: | < 0.3 at v = 3m/s and initial deflection = 15° | As type X123.000M, but with high performance heating | X123.010M |
| Power supply: | | | |
| Electronic: | 12...30 V DC; approx. 50 mA; 4.8...30 V DC, approx. 1.0 mA at 12 V for type X123.000M | As type X123.100M, but with high performance heating | X123.110M |
| Heating: | 12 V DC; 1.0 A | | |
| High performance heating: | 24 V DC; 2.7 A | | |
| Output signal: | digital, 8 Bit Gray Code as serial data, RS232 compatible, Additional at version X123.100M: | | |
| | analogue: 0...20 mA | | |
| | 4...20 mA | | |
| | 3- phase signal (selyn motor system) suitable for analog instruments | | |
| | admissible load: approx. 400 Ω | | |
| | Heating: 6 W controlled by thermostat | | |
| | High performance heating: max 60 W | | |

Wind Direction Sensor, small version

Wind vane coupled to potentiometer, 0...1 kΩ, corresponding 1...359°. Compact design with built-in heating resistor; low weight and low cost.



| | | | |
|------------------|---|--|------------------|
| Meas. range: | 360° | Wind Direction Sensor, heated, with potentiometer 0...1 kΩ | X191.100M |
| Max. load: | 60 m/s | | |
| Threshold: | <1 m/s at 90° | | |
| | initial deflection | | |
| Power supply: | 12 V DC; max. load 1.5 W | | |
| Heating: | 12 V DC; approx. 2 W | | |
| Output signal: | 0...1 kΩ | | |
| Linearity: | ±0,3% | | |
| Dimensions: | Housing Ø: 50 mm, height 210 mm, vane turning radius 187 mm | | |
| Weight: | approx. 280 g | | |
| Installation: | Side bar with 2 holes Ø 6.5 mm | | |
| Connection: | IP 67-connector | | |
| Operating temp.: | -30...+65°C | | |

Type No.

Ultrasonic Anemometer 2D

X300.000M



for 2 dimensional detection of wind direction and wind speed without moving parts. Measurement by means of two orthogonal positioned ultrasonic measuring paths. The complete electronic for signal processing and -analyzation is contained in a compact stainless steel housing.

| | | |
|--------------------|-------------------------------------|---------------------------------------|
| Meas. range, max.: | Wind speed: | 0...60 m/s |
| | Wind direction: | 0...360° |
| | Temperature: | -40...+70°C |
| Accuracy: | Wind speed: | ±5% of FS |
| | | ±3% of FS with individual calibration |
| | Wind direction: | ±3° |
| Output: | Serial: | RS232 resp. RS422/RS485 |
| | Analog: | 0...10 V and 0...20 mA, alternat. |
| | | 0...10 V and 4...20 mA |
| Power supply: | 24 V DC; sensor 2,5 W | |
| | heating 60 W (optional) | |
| Dimensions, max.: | Ø 300 mm x 540 mm length | |
| Weight: | approx. 3.1 kg | |
| Connection: | Metal connector, IP 67 | |
| Fastening: | Socket Ø 34 x 40 mm length | |
| | Socket with hole Ø 48 mm (optional) | |

Ultrasonic Anemometer 3D

X302.000M



for 3 dimensional detection of wind speed and wind direction; without moving parts. Compact design with aluminium housing and stainless steel tubes. Heavy duty version (with outline frame), as well as further options, upon request.

| | | |
|-------------------|--------------------------------------|--------------------------|
| Meas. range: | Wind Speed: | 0...45 m/s |
| | | extentable to 0...60 m/s |
| | Wind direction: | 0...360° |
| | Temperature: | -30...+50°C |
| | Wind components x,y,z: | 0...45 m/s |
| Output: | RS 232 or analog 0...10 V (optional) | |
| Power supply: | 24 V DC; Sensor 2.5 W | |
| | Heating 60 W (optional) | |
| Dimensions: | Ø 320 mm x 800 mm length | |
| Weight: | 2.3 kg | |
| Connection cable: | approx. 12 m | |

Combined Sensor for Wind Speed and Wind Direction

combination from types X021 resp. X034 (wind speed) and X121 resp. X122 (wind direction). Frame and socket made of black anodised aluminium. Further technical data corresponding with the single sensors



| | |
|---------------------|---|
| Max. load: | 60 m/s |
| Dimensions: | Height approx. 825 mm, turning radius of wind vane: approx. 350mm |
| Heating (optional): | 12 V, 2 x 6 W, controlled by thermostat |
| Connection: | IP 67 connector |
| Fastening: | Socket with Ø 48mm hole |
| Operation temp.: | -35...+80°C |

| | |
|---|------------------|
| Combination from WS Sensor X034.000M and WD Sensor X122.000M: | X400.000M |
| Combination from WS Sensor X034.100M and WD Sensor X122.100M: | X400.100M |
| Combination from WS Sensor X021.000M and WD Sensor X121.000M: | X400.200M |
| Combination from WS Sensor X021.100M and WD Sensor X121.100M: | X400.300M |

Type No.

Combined Sensor for Wind Speed and Wind Direction



combination from types X035 (wind speed) and X123 (wind direction). Frame and socket made of black anodised aluminium. Further technical data corresponding with the single sensors.

- Max. load: 100 m/s
- Dimensions: height approx. 775 mm , turning radius of the wind vane: approx. 350 mm
- Heating: 12 V, 2 x 6 W controlled by thermostat; high performance heating 24 V/60 W
- Connection: metal connector, IP 67
- Fastening: Socket with \varnothing 48 mm hole
- Operating temp.: -25...+80°C, with high performance heating -40...+80°C

| | |
|--|------------------|
| Combination from WS Sensor X035.000M and WD Sensor X123.000M: | X500.000M |
| Combination from WS Sensor X035.010M and WD Sensor 4X123.010M: | X500.010M |
| Combination from WS Sensor X035.100M and WD Sensor 4X123.100M: | X500.100M |
| Combination from WS Sensor X035.110M and WD Sensor 4X121.110M: | X500.110M |

Hand Cup Anemometer



hand held instrument, for manual measurement of wind speed. Black ABS housing, 4 different large scales.

- Meas. range: 0...35 m/s
- 0...70 kn
- 0...120 km/h
- 0...12 Bft.

X651.000M

Indication Instrument for Wind Speed



moving coil instrument in metal housing suitable for control panel installation; analog scale m/s and kn; illuminable.

- Meas. range: 0...41 m/s (inner scale)
- 0...80 kn (outer scale)
- Division: 1 m/s resp. 2 kn
- Meas. element: I = 1 mA, Ri = 1 k Ω , resp. 20 mA
- Scale: 240° analog
- Dimensions: See ordering code
- Weight: Dep. upon version max. approx. 1.3 kg

Indication Instrument for Wind Speed

| | |
|-------------------|------------------|
| size 96 x 96 mm | X710.100M |
| 1 mA | |
| size 96 x 96 mm | X710.110M |
| 20 mA | |
| size 144 x 144 mm | X710.200M |
| 1mA | |
| size 144 x 144 mm | X710.210M |
| 20 mA | |

Indication Instrument for Wind Direction



three-coil receiver, instrument in metal housing, suitable for control panel installation, illuminable.

- Meas. range: 0...360° resp.
- 180° P and 180° Stb
- Division: 10°; N, NE, E, SE, S, SW, W, NW
- Dimensions: See ordering code
- Weight: Dep. upon version max. approx. 1.2 kg

Indication Instrument for Wind Direction

| | |
|----------------------|------------------|
| size 96 x 96 mm | X720.000M |
| size 144 x 144 mm | |
| meas. range 0...360° | |
| meas. range 2 x 180° | |

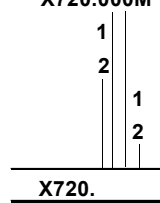

X720.

Type No.



Combined Indication Instrument

for simultaneous indication of wind direction (analog) and wind speed (digital) in metal housing for panel installation Selection m/s – kn is possible.

Meas. range WD: 0...360° resp.
180° P and 180° Stb, division 10°
Meas. range WS: 0...41 m/s = 0...80 kn
LED display, 3½ -digit
7-segment, height. 13.5 mm
Illumination: 2 x 12 V, 1 W
Dimensions: 144 x 144 mm, depth 125 mm
Weight: approx. 1.4 kg
Power supply: 230 VAC / 50 Hz
Output: 12 V DC, 1.5 VA for supply of wind direction sensor;
12 V DC, 12 VA for heating supply
WS and WD;
for Type 4733.1--- additional output for ext. selection switch and dimmer
Signal input: 0...1 mA resp. 0...20 mA for WS; 3 phase-signal (selsyn motor system) for WD

Combined Indication
Instrument WS/WD

as above, with ext.
panel with selection
switch m/s-kn and
dimmer

meas. Range WD
180° P and 180° Stb

X733.000M

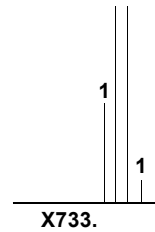

*All Sensors of this group can be directly connected to Datenloggers (refer to product group 1).
For display of wind parameters on a PC or screen various software programs are available (refer to product group 1)*

Masts, crossarms and further accessories: Refer to product group 9

Wind direction and wind speed sensors X36789 / X36799

Very economical in acquisition is this wind sensor pair... Furthermore, the wind sensors impress with high accuracy, simplest mounting methods and ultimately robust, seawater-proof materials.

The heated wind sensors are equipped with an optimal heating of the wind sensor head to provide the minimum of power of the system by thermal decoupling of the housing shaft.

The low power sensors are especially suitable for use at solar powered applications.

- Precision, tradition and future reliability
- Large operative measuring and temperature range
- Simplest mast mounting of wind sensors
- Very good starting values through magnetic, contactless measuring principle
- Wind sensors with optimal heating concept
- Wind sensors for low power applications



Application fields of these wind sensors e. g.:
Wind power plants - building services - wind warning devices on cranes - industrial applications - in all climatic zones - environmental measurements

Standard Line

Wind Sensors INDUSTRIAL

| | |
|-----------------------|---|
| Measuring principle: | Hall sensor array |
| Range of application: | Temperatures -30...+70°C heated - wind speed 0...60 m/s |
| Supply voltage: | 24 VDC (20...28 VDC) · max. 800 mA - heating · electr. controlled |
| Housing: | · 18 W Seawater-resistant aluminium · anodized · IP 53 · Ø 32 mm |
| Included in delivery: | bore Ø 30 mm for mounting at traverse 1 sensor · 1 cable for plug connection · 12 m · ready-made |
| | The wind sensors are connectable to data loggers |

| Parameters: | Wind direction (X36789) | Wind speed (X36799) |
|--------------------------------|--|--|
| Measuring element: | Blade wind vane - stably fibre-reinforced plastics | 3-armed cup rotor - fail-safe |
| Measuring range: | 0...360° | 0.7...50 m/s |
| Accuracy: | < ± 2% | ± 2% FS |
| Resolution: | 5.6° | < 0.02 m/s |
| Starting value: | < 0.7 m/s | < 0.7 m/s |
| Outputs: | 0/4...20 mA - max. load 600 Ω | 0/4...20 mA = 0...50 m/s - max. load 600 Ω compensated |
| Dimensions: | Wind vane L 232 mm · H 307 mm | Cup rotor R30 mm · H 230 mm |
| Weight: | Approx. 0.35 kg | Approx. 0.25 kg |
| <u>Varieties:</u> | Id-No. | Id-No. |
| Output 0..500 Hz | | X36799272 |
| Output 4..20 / 0..20 mA | X36789262 / X36789222 | X36799262 / X36799222 |

Low power wind sensors with 0...2 V output (without heating)

| | | |
|-----------------------|--|------------------|
| Id-No. | X36789282 | X26799282 |
| Measuring ranges: | 0...360° | 0.7...35 m/s |
| Current consumption: | 4 mA | 6 mA |
| Range of application: | Temperatures 0...+70°C • -30...+70°C at non icing conditions | |
| Supply voltage: | 10...28 VDC | |
| Output: | 0...2 VDC | |

| | |
|---------------------|-------------------------------------|
| <u>Accessories:</u> | Masts and Power supply units |
| X36789228 | Mast adapter · Ø 50 mm |
| X36789232 | Traverse |

Wind Sensors Fully Heated X050.000M

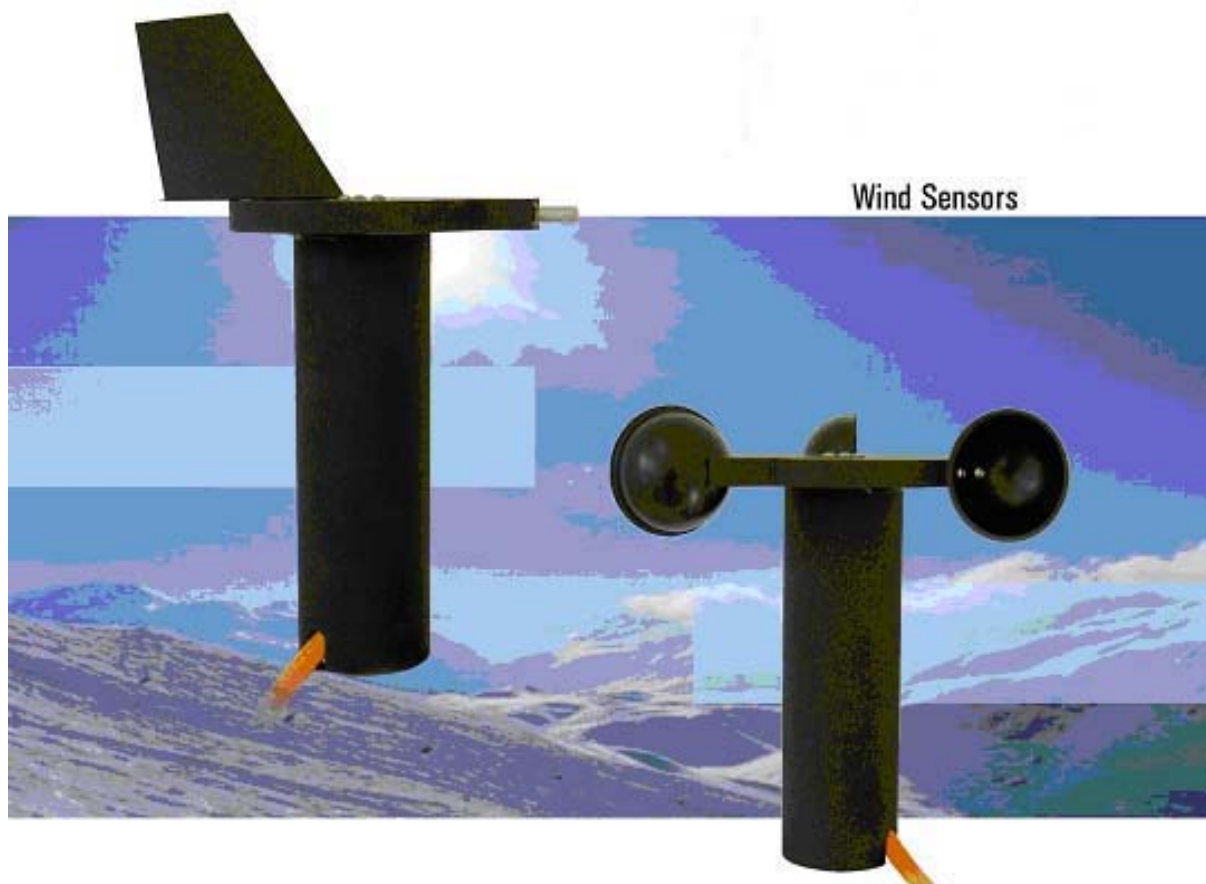

The fully heated wind sensor

- robust sensor for reliable measurement of wind direction and wind speed at extremely low temperatures
- contactless measuring principle „Magnetical Positioning Encoder System“ (MPES) for wear resisting, precise acquisition of measuring data
- highest loading capacity and longevity through special mode of bearing and special alloys.
- special blade wind vane and 3-armed cup made of dimensionally stable and break-proof aluminium.
- easy mounting principles for mast, flange or bore for high flexibility
- heating supplied separately from sensor electronics- for operation at lowest temperatures
- integrated 125 watts- heating for optimal heating of the moving parts

Features and Advantages

- more than 140 years of experience in classical meteorology and professional ship meteorology
- excellent quality plus optimal price- performance ratio
- frictionless acquisition of measuring data through contactless measuring principle.
- seawater resistant surfaces for high product longevity
- wide measuring range of 0,4...50m/s.

- especially low starting values 0,4m/s.
- high resolution of the measuring data
- fully heated sensor for use at extremely low temperatures
- Optimized heating construction with regard to flow

1 Introduction

The X050.000M is a very robust, compact and extremely reliable wind sensor. The system is specially designed for use under extremely low temperatures.

The X050.000M includes experience in development and production of wind sensors of more than 140 years.

The system measures and processes the following meteorological parameters: wind speed and wind direction.

All measuring parts and the other system components are integrated in the sealed, water-proof housing.

The X050.000M wind sensor is particularly designed for use under icing climate conditions. The 125 Watts heating allows the operation of the sensor within a wide temperature range of -40 to +70°C **even under icing conditions.**

2 Setting to work

The wind can be represented by a vector quantity. For a complete description of the wind it is necessary to specify its speed and direction. The two components are subject to spatial and temporal variations; thus, strictly speaking, they are valid only for the site where the measuring instrument is installed. We therefore recommend to select the place of installation very carefully.

2.1 Installation conditions

2.1.1 Generally

Generally, wind measuring instruments should not measure the specific wind conditions of a limited area, but indicate the typical wind conditions of a wider area. The values measured at different places must be comparable. Thus, when installing the sensor you should make sure the place of installation is not under the lee of great obstacles. The distance between the obstacles and the sensor should be 10 times the height of the obstacles (this corresponds to the definition of an undisturbed terrain). If an undisturbed terrain of this kind does not exist the sensor must be put up at a height of at least 5 m above the obstacle height. If the sensor must be installed on a roof top the place of installation must be in the middle of the roof to avoid predominant wind directions. If you want to measure both wind direction and wind speed, the sensors should be installed at the same measuring point and mutual influence of the sensors should be avoided. The sensor pair X050.000M with its ar-

range of sensors next to each other easily meets this requirement.



The sensor must not be installed onto transmitting plants or antennas or close to them. A minimum distance of 2 m is to be kept for interference-free signal transfer.

2.2 Tools and installation aids

There are no special tools or materials required for the installation works. All work can be carried out with standard tools available in a regular workshop.

2.3 Unpacking the sensor

The sensor is packed in a separate box, carefully protected against mechanical influences during transport.

Please verify that the following parts and documents are enclosed:

- 1 sensor X050.000M
- 1 operating manual

Accessories: (depend on order size, in all cases separately packed)

Connecting cable with plug and core cable ends.

2.4 Goods inspection

Please thoroughly check the delivery with regard to completeness and eventual transport damages. In case of eventual claims please contact us in writing immediately.

2.5 Power supply

At the input connector the sensor requires a 24 volt nominal DC power source (20...28 V_{DC}) for operation. The heater of the X050.000M has to be supplied with 24 volt DC and has a power consumption of 125W.

2.6 Installation variants



Attention! Because the installation takes place in a dangerous height, the assembly personnel must follow the rules for prevention of accidents.

2.6.1 Mast or pipe mounting



Make sure the device is easily accessible so that you can set up the north direction for the wind direction sensor and perform any maintenance work. To reach the sensors use a ladder of the appropriate length or a telescope working platform of the appropriate height.



Ladders or other lifting helps must be absolutely in order and must guarantee a secure support! Follow the rules for prevention of accidents.

Mount the sensors at the top of grounded tube with an outer diameter \varnothing 48-50 mm. The mast adapter (see accessories) is obligatory.

1. Remove both thread nuts from the sensor.
2. The sensor with cable-plug connection is led without cable into the bore.
3. Attach the sensor with the flat side of detached nut from the lower side. Tighten with a suitable tool (wrench size 36), until a twisting safety of the sensor aligned to the north is given.

You can also use masts that can turn around their vertical axis or masts consisting of individual segments or telescoping masts that you can secure after setting up the north direction.

If wind speed and wind direction are measured at the same time, the measurement generally takes place not only at the top of a mast but also at the end of a cross arm. The arms must stay torsion-free and vibration-proof even at high wind speeds and must be accessible for you to perform mounting and maintenance work.



When you install the connecting cables make sure not to excessively shorten the cable leading to the connector in the lower part of the sensor casing so that you can later maintain or dismount the sensor. Further put a cable loop as sensor protection against water under the sensor.



Tip: Install the sensors on ground to the traverse and align the wind vane parallel to the traverse. Only then go upward in order to accordingly align the sensors with traverse under assistance of a partner on ground.

2.6.2 Traverse with bore hole

(Ident-No.: X14567.010)

At each end of the traverse there are bores with a slot and with a \varnothing 30 mm

1. Remove the lower nut from the sensor.
2. Put a sensor with assembled cable sidewise into the bore.
3. Attach the sensor with the flat side of detached nut from the lower side. Tighten with a suitable tool (wrench size 36), until a twisting safety of the sensor aligned to the north is given.

2.6.3 Generally mounting in bores

Material thickness for installation of the sensor between the nuts may be max. 10 mm.

1. Remove the lower thread nut from the sensor.
2. The sensor with cable-plug connection is led without cable into the bore and fastened by the opposite side with the loose nut as under chapter 2.6.1 point 3.
3. The loose nut is now to be touched with the flat side first over the cable in order to fasten the sensor as under chapter 2.6.1 point 3.

2.6.4 North alignment of wind vane

For wind direction measurements the north mark on the sensor must be aligned with the geographical north direction.

You have to turn the marking exactly over the marking at the sensor shaft. When you have aligned the marks, you may fix the wind vane with e.g. a piece of adhesive tape. After alignment the adhesive tape has to be removed. When you have fixed the wind vane you can locate the reference point by aiming at it over the axis. Now you must turn the sensor casing on the mounting tube until the tip of the wind vane points to the reference point in the north.

To set up the sensor's north orientation select a landmark which is as far as possible up north with regard to the final position of the wind direction sensor.

The reference point can be selected using a topographical map (1:25000). The exact position of the reference point is determined using an amplitude compass that can be adjusted horizontally on a stand.



Compass declination has to be considered!

When the north direction is set up for the wind direction sensor, you can mount it like under point "Installation variants".

A functional check at three rotated 90° directions is recommended.

If you cannot select a northern reference point owing to local conditions, you can proceed analogously using a reference point in the south. In this case, however, you have to make sure the north mark on the sensor does not point to the reference point but in the opposite direction.



Note: Follow all safety instructions while setting up the sensor onto a mast.



To reduce the risk of inductive interference the sensor must be properly grounded (screening on both sides)..

2.6.5 Power and signal connection

The X050.000M sensors dispose of separate connections for the heating supply and for the supply and signal transmission of the sensor.

2.6.5.1 Connection of sensor electronic

Sensors X050.000M are connected to a data measuring system via the open cable end (see next page). The connecting cable is suitably led along the mast between the data evaluation device (indicating instrument or data acquisition system) and the sensor. The cable must be fastened using appropriate cable ties (their length depends on the mast diameter).

2.6.5.2 Connection of heating

The supply of the sensor heating is connected via an extra cable which is lead out on the sensor side.

The cable routing should be arranged in accordance with the installation site. Make sure that the cable is secured by suitable cable binders.

For further details about the electrical connection of the sensor please see paragraph „Dimensional drawings and electrical connections“.



Tip: Lead the cable in a wide curve from the mast to the bottom of the casing so that you can later easily dismount the cable. Please make sure the cable is protected from humidity on the side of the data processing system. Generally, cable sockets that use a rubber joint to prevent humidity from penetrating into the terminal box of the data processing system provide sufficient protection.



Example:
Cable routing through EMC- compatible Pg-socket

2.6.6 Safety instructions



As the sensor is often mounted at considerable heights, the appropriate safety instructions need to be observed in the course of mounting.. During electrical installation works the respective AC/DC must be switched off.

The housing must not be opened by unauthorized personnel!

3 Maintenance

The sensor design permits long periods of maintenance-free operation. We therefore recommend a regular visual verification and functional test of the wind sensors as well as a sensor calibration of both sensor types in regular intervals of 4 years.

In case of specific problems or difficulties do not hesitate to contact our service center

4 Transports

In case it is necessary to ship or to transport the sensor, the same must be carefully packed to prevent eventual transport damages.

5 Dimensional drawings and electrical connections

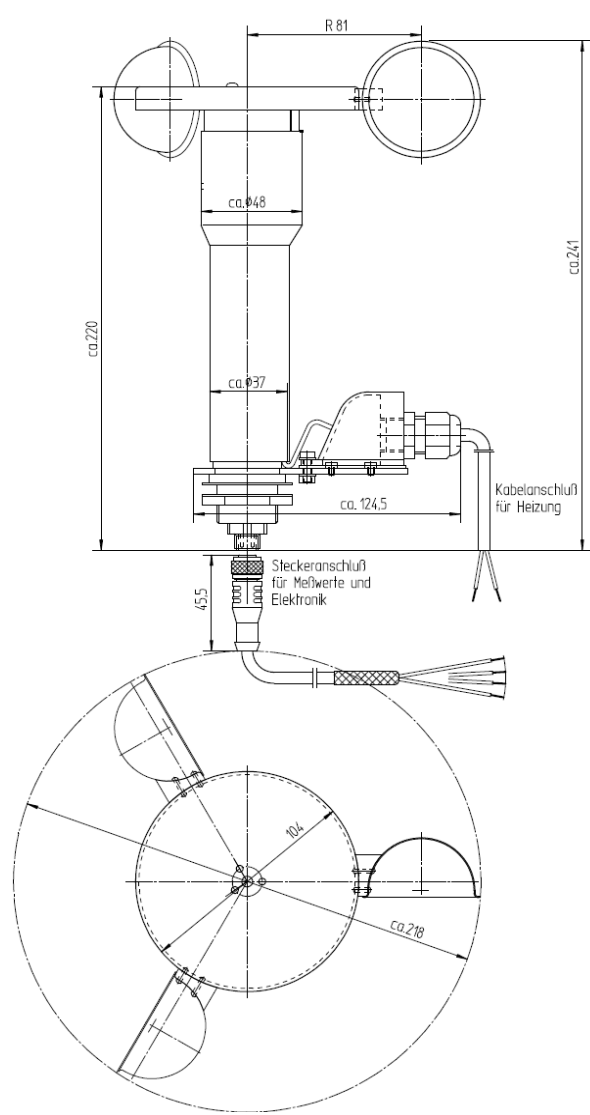
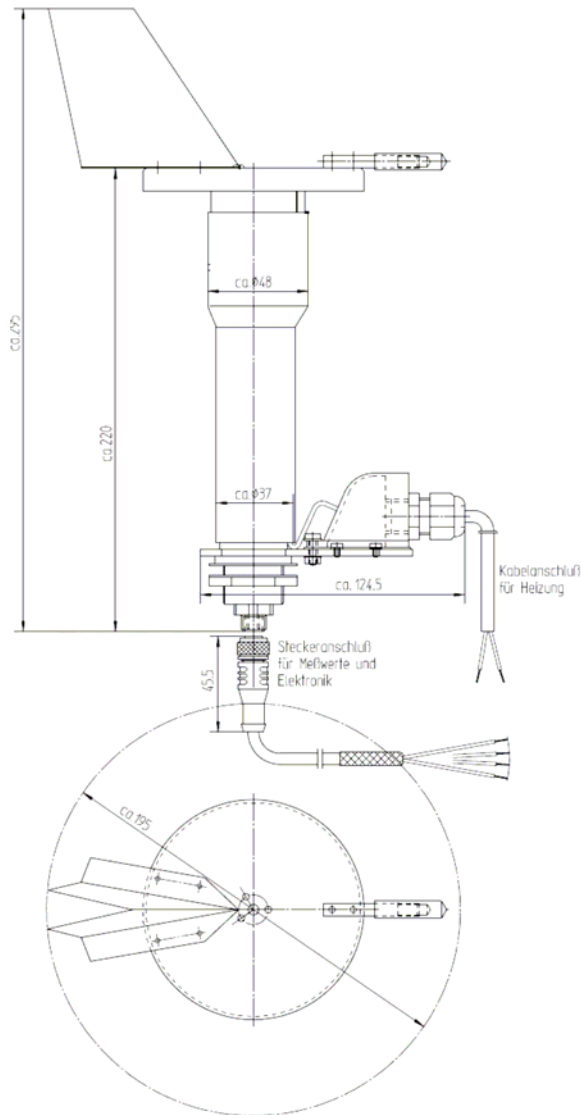

Example:

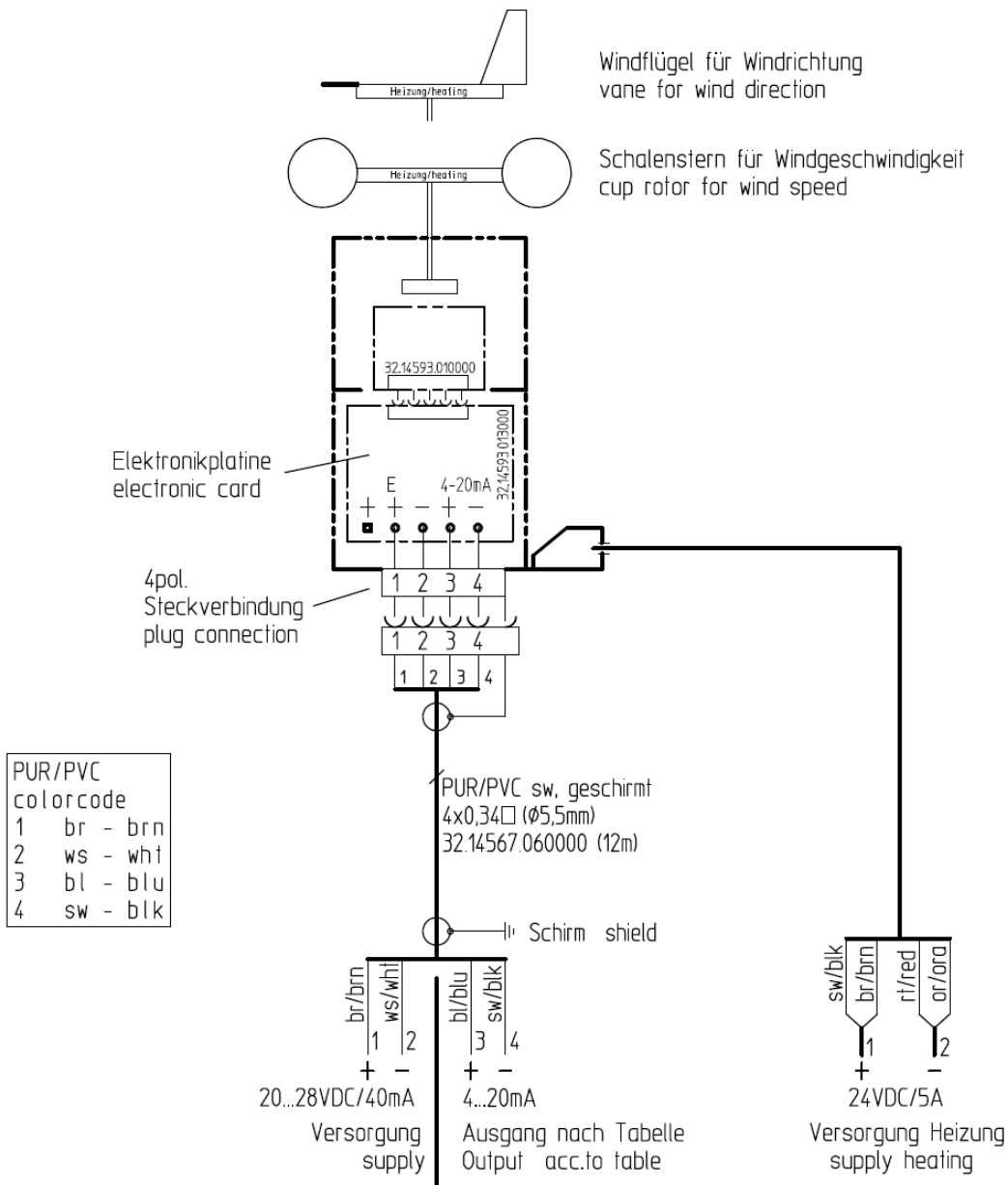

| | |
|---|----------------------|
| mt Steckverbinder wth plug connector | |
| Windrichtung wind direction | Ausgang / output |
| No. X051.000M | 4...20mA = 0...360° |
| Windgeschwindigkeit wind speed | Ausgang / output |
| No. X050.000M | 4...20mA = 0...50m/s |

6 Technical data

Maximum heated wind sensor X050.000M

| | |
|-----------------------|--|
| Meas. principle: | „Magnetical Positioning Encoder System“ (MPES) |
| Meas. range: | Temperature -40...+70°C maximum heated • Wind speed 0...75 m/s • humidity 0...100% r. F. |
| Output | 4...20mA • 4 Hz update rate |
| Supply voltage: | Sensor 24 V _{DC} (20...28 V _{DC}) • heating controlled by bimetallic switch, 24 V _{DC} , 125 W |
| Housing: | saltwater-proof aluminium • especially-anodized • IP65 in upright position |
| Dimensions: | see dimensional drawings |
| Weight: | Approx.. 0,8 kg |
| Included in delivery: | 1 Sensor • 12m cable with connector (sensor) • 12m cable (fix connected to heating) |

Parameter wind direction

Ident-No.: X051.000M

| | |
|-----------------|--|
| Parameter: | wind direction in ° |
| Meas. element: | Wind vane • inherently aluminium • special surface |
| Meas. range | 0...360° |
| Accuracy: | ± 1 % |
| Resolution: | < 3° dynamic |
| Starting value: | 0.4 m/s |
| Damping ratio: | N/A |

Parameter wind speed

Ident-No.: X050.000M

| | |
|------------------|--|
| Parameter: | Wind speed in m/s |
| Meas. element: | 3-armed cup anemometer • aluminium • special surface |
| Meas. range | 0.4...50 m/s |
| Accuracy: | ± 2% FS at 0.4...50 m/s |
| Resolution: | < 0.1 m/s |
| Starting value: | < 0.4 m/s (compensated) |
| Delay distance:: | N/A |

Wind Speed & Direction Sensor X200.000M



ALL WEATHER SENSING TECHNOLOGY

MAINTENANCE FREE - 2 YEAR WARRANTY

- LOW START SPEED
- CORROSION FREE, UV STABLE MATERIAL
- NO CALIBRATION REQUIRED
- ROBUST CONSTRUCTION
- TRUE 0-359° OPERATION (no dead band)
- WIND SPEED & DIRECTION FROM A SINGLE UNIT
- AGRICULTURE
- WIND POWER
- POLLUTION CONTROL
- PORTABLE WEATHER STATIONS
- ROADSIDE WEATHER STATIONS
- TUNNELS
- MARINE

ULTRASONIC WIND SENSOR X200.000M

A real low cost alternative to conventional cup / vane / propeller wind sensors in a single unit.

The X200.000M is based on highly successful, proven ultrasonic technology. Ideal for applications that demand economic wind sensing, it is suitable for land-based and marine environments.

As a lightweight unit the X200.000M is of a robust, high strength construction designed to withstand installation and use with no fear of the damage commonly experienced with more fragile cups, vanes or propellers. Without the need of expansive on-site calibration or maintenance and with a corrosion free exterior, it is a true fit and forget unit.

The flexible design enables to easily configure the X200.000M to deliver the information you require. By separate configuration it is possible to select the output rate and choose the units of measurement that suit your application. Ensuring accuracy and reliability, it automatically transmits an anemometer status code with each output to indicate its operating status. Available in four options, providing a number of different digital and analogue outputs.

Maintenance free, quick and easy to install, the X200.000M is designed to be mounted using a standard pole fitting and comes complete with all screw fittings, a mating marine grade connector and comprehensive user manual.

The unit is supplied with a 2 year warranty as standard.

SELECTABLE

Output 1, 2 or 4 outputs per second

Parameters Wind Speed & Direction or
U and V (vectors)

Units of Measure m/s, knots, mph, kph, ft/min

WIND SPEED

Range 0 – 60 m/s (116 knots)

Accuracy +/- 2%

Resolution 0.01 m/s (0.02 knots)

WIND DIRECTION

Range 0 to 359° – no dead band

Accuracy +/- 3°

Resolution 1°

ANEMOMETER STATUS

Message supplied as part of standard output

POWER REQUIREMENT

Anemometer 9-30Vdc @ 14.5mA typical

Start up time <1 second

OUTPUTS

Option 1 RS232

Option 2 RS232 + RS422 + RS485 + NMEA*

Option 3 RS232 + RS422 + RS485 + NMEA*
+ 0-5V or 4-20mA

Option 4 SDI-12

* NMEA 0183 Version 3

ENVIRONMENTAL

Ingress Protection IP65

Operating Temperature -35°C to +70°C

Storage Temperature -40°C to +90°C

Operating Humidity <5% to 100%

EMC EN 61000-6-2 : 2001

EN 61000-6-3 : 2001

MTBF

15 years

MATERIALS

External Construction LURAN S KR 2861/1C ASA/PC

DIMENSIONS

Size 142 x 160 mm

Weight 0.45 kg

WARRANTY

2 years

OPTIONAL FACTORY CALIBRATION

Traceable to national standards

ACCESSORIES

Pipe Mounting 44.45 mm (1.75 in) diameter

Cables

Display

Housing color white

- Cost attractive solution for horizontal wind speed and direction measurement
- No moving parts, first class accuracy and stability, compact, durable and robust
- Heated version available
- Triangular design ensures excellent data availability and 360° measuring accuracy
- Maintenance free
- Corrosion resistant, IP65 housing
- Applications in meteorology, marine, wind power, agriculture



Maintenance

The X220 has no moving parts, thus making it superior to the conventional mechanical wind sensors. It is also very economical; there is no need for field calibration or maintenance.

the settings, such as averaging times, output mode, update intervals, measured variables, and message contents.

Heating

Wind can also be measured in freezing weather and during snowfall, thanks to the optional heating available

Accurate measurement

The triangular design in the X220.000M solves the mechanical shading of transducers on measurement paths. This ensures accurate wind measurement from all wind directions, without blind angles or corrupted readings.

The X220 is free from problems the conventional mechanical sensors often have such as inertia, friction, time-constant, over-speeding, and starting threshold.

Easy settings

The X220 is supplied pre-configured from the factory. With the Configuration Tool you can change

As the heating circuit is separate from the operational power, separate supplies can be used. Heating is switched on automatically only at low temperatures.

Flexible output options

The X220 communicates with the host via a bi-directional serial line. It offers a choice of four configurable serial interfaces: SDI-12, RS-232, RS-485, and RS-422. The screw terminals inside the lower part of the transmitter are easy to access.

An industry standard 8-pin M12 connector is optionally available.

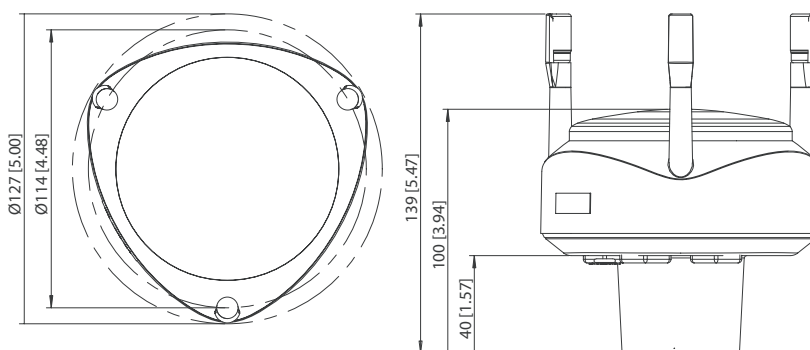

Technical Data

The X220 has a wide supply voltage range, 5.3 ... 30 VDC, which is applicable both to the operational and heating power.

Easy installation

The X220 can be mounted either on top of a 30 mm pole mast (or 3/4" pipe when using optional mounting adapter) or on a cross arm.

The X220 is easy to install - it only needs to be mounted, aligned, and connected to the host system and the power source.

When using the optional mounting adapter, no new alignment is required, not even after re-installation of the sensor.

Electromagnetic compatibility

Complies with EMC standard: EN61326-1; 1997 + Am1: 1998 +AM2:2001 Generic Environment

Wind

Wind speed

| | |
|---------------------|---------------------------------------|
| Range | 0 ... 60 m/s |
| Response time | 0.25 s |
| Available variables | average, minimum, maximum |
| Accuracy | ±0.3 m/s or ±3 % whichever is greater |
| 0 ... 35 m/s | ±5 % |
| 35 m/s ... 60 m/s | virtually zero |
| Starting threshold | 0.1 m/s (km/h, mph, knots) |
| Output resolution | m/s, km/h, mph, knots |
| Units available | |

Wind direction

| | |
|---------------------|------------------------------|
| Azimuth | 0 ... 360° |
| Response time | 0.25 s |
| Available variables | average, maximum and minimum |
| Accuracy | ±3° |
| Starting threshold | virtually zero |
| Output resolution | 1° |

Measurement frame

| | |
|-----------------|---|
| Averaging time | 1 ... 3600 s (=60 min), at one second steps on the basis of samples taken at 4 Hz rate (configurable) |
| Update interval | 1 ... 3600 s (=60 min), at one-second steps |

General

| | |
|-------------------------|--|
| Self-diagnostics | separate supervision message, unit/status fields to validate measurement quality |
| Start-up | automatic, <10 seconds from power on to the first valid output |
| Serial data interfaces | SDI-12, RS-232, RS-485, RS-422 |
| Communication protocols | SDI-12 v1.3, ASCII automatic & polled, NMEA 0183 v. 3.0 with query option |
| Port | |
| Baud rate | 1200 ... 115 200 |
| Operating temperature | -52 ... +60 °C (-60 ... +140 °F) |
| Storage temperature | -60 ... +70 °C (-76 ... +158 °F) |
| Dimensions | |
| height | 139 mm (5.47") |
| diameter | 127 mm (5.00") |
| weight | 510 g (1.12 lbs) |
| Housing | IP65 |

Power supply

| | |
|------------------------------|---|
| Input voltage | 5.3 ... 30 VDC |
| Power consumption on average | |
| minimum | 0.07 mA at 12 VDC |
| maximum | 13 mA at 30VDC |
| typical | 3 mA at 12 VDC |
| Heating voltage options | (default measuring intervals) DC, AC, full wave rectified AC |

Specifications are subject to change without prior notice.

Wind Speed & Direction Sensor X400.000



- ULTRASONIC TECHNOLOGY
- MAINTENANCE FREE
- ROBUST CONSTRUCTION
- HEATED HEAD CABS
- LOW TEMPERATURE DE-ICING
- USER SELECTABLE OUTPUT FORMAT
- TRANSPORT SAFETY
- WIND TURBINE CONTROL
- SHIPDYNAMICPOSITIONINGSYSTEMS
- AIRCRAFT LANDING SYSTEMS
- METEOROLOGICAL SYSTEMS
- STRUCTURAL SAFETY

The wind sensor X400.000M provides the best solution on the market for reliable, accurate and cost-effective wind speed and directional measurement. It combines the latest advances in ultrasonic technology together with long term experience.

The elimination of moving parts, together with a rugged stainless steel construction means that the X400.000M is virtually maintenance free and requires no calibration on site. The heated head keeps the unit free from ice and snow, providing continuous use even in the most extreme weather conditions.

A new flexible design ensures that the X400.000M can be configured by the user to their exact requirements, which

may include analogue outputs, 10 Hz output, heating or sonic temperature.

The communications package allows the user to operate the anemometer in various modes, permitting the measurement of U & V vectors or wind speed and direction.

Communication is via an RS422 bidirectional link, which allows several units to be networked together and data to be logged on demand. The X400.000M has been rigorously tested to internationally recognised standards and meets the stringent performance criteria specified by airport, marine, oil, production, wind power, meteorological and utility organisations worldwide.

DIMENSIONS

Size 405mm x 210mm
Weight 1.5kg

MEASUREMENT

Output 1Hz, 4Hz, 10Hz
Parameters UV, Polar, NMEA, Tunnel
Units m/s, Knots, MPH, KPH ft/min
Averaging Flexible 1-3600 seconds

WIND SPEED

Range 0 - 65 m/s (0 - 145mph)
Starting Threshold 0.01 m/s
Accuracy 2%
Resolution 0.01 m/s
Offset ± 0.01 m/s

DIRECTION

Range 0 - 359°
Dead Band Direction None
Accuracy $\pm 2^\circ$
Resolution 1°

SONIC TEMPERATURE

Range -40°C to + 70°C (refer to user manual)

DIGITAL OUTPUT

Communication RS422, full duplex
Baud Rates 1200 2400 4800 9600 19200 38400
Formats 8 data, odd, even or no parity
Anemometer Status Supplied as part of standard message

ANALOGUE OUTPUT - OPTIONAL

Quantity 3 (speed, direction, status or sonic temp)
Scale Multiples of ± 10 m/s up to 70 m/s
Type $\pm 2.5V$, 0 - 5V or 4 - 20mA
V output resistance 60 Ohms
4 - 20mA loading 10 - 300 Ohms

MATERIALS

External Construction Stainless Steel 316

ENVIRONMENTAL

Moisture Protection IP66 (NEMA4X)
Operating Temperature -55°C to +70°C
Humidity 5% to 100% RH
Precipitation 300mm/hr
EMC EN 61000-6-2 : 2001
EN 61000-6-3 : 2001

Icing MILSTD810E Method 521.1 Procedure 1

MISC

Standards Traceable to NAMAS standards
Site Calibration None Required
Integrity Check Unit (Zero Wind) supplied as optional extra

POWER REQUIREMENT

Anemometer only 9-30 V DC (40mA @ 12 V DC)
Heating Optional 3A @24V AC or DC

Type No.

X002.000M



Barotransmitter

Precision version with ceramic sensing element. Capacitive measurement. Analog output. 4-line connection. Fast response. Excellent repeatability and long term stability. Installation independent from sensor position. Compact dimensions, low weight and low power consumption.

- Measuring range: 800...1060 hPa; *other ranges upon request*
- Accuracy: ± 0.2 hPa at ambient temperature $20 \pm 5^\circ\text{C}$
- Long-term stability: ± 0.1 hPa / year
- Operating temperature: $-40...+60^\circ\text{C}$
- Supply: 10...30 V DC, < 4 mA
- Output: 0...5 V DC, $R_a \geq 10$ k Ω
- Hose connection: $\varnothing 5$ mm
- Dimensions: approx. 100 x 60 x 22 mm
- Weight: approx. 130 g



Barotransmitter

Version with piezoresistive sensing element, analog output. Compact design, low weight and low power consumption. Optional versions with amplifier (voltage – respectively voltage – and current output).

- Measuring range: 900...1050 hPa; *other ranges upon request*
- Accuracy: ± 1 hPa at ambient temperature $20 \pm 10^\circ\text{C}$
- Operating temperature: $-25...+70^\circ\text{C}$
- Supply: 8...16 V DC, approx. 10 mA (Version 5004.0000)
11...28 V DC, approx. 46 mA (Versions 5004.1000 and .2000)
- Output: 0.3...4.9 V DC (Version 5004.0000)
0...5 V at >10 k Ω (Version 5004.1000)
0...5 V at >10 k Ω and
4...20 mA at 0...500 Ω (Version 5004.2000)
- Dimensions: 70 x 50 x 35 mm, weight approx. 75 g (Version 5004.0000)
115 x 63 x 40 mm, weight approx. 190 g (Versions 5004.1000 and .2000)

Barotransmitter with piezoresistive sensing element **X004.000M**

Barotransmitter with piezoresistive sensing element, with amplifier 0...5 V output **X004.100M**

Barotransmitter with piezoresistive sensing element, with amplifier 0...5 V and 4...20 mA output **X004.200M**

Barotransmitter with Digital Display



for indicating the absolute air pressure, design with piezoresistive sensing element, optional with voltage or current output for electrical transmission of the absolute air pressure, suitable for control panel installation.

- Display: LED 4 ½ digit., height of charact. 13.2 mm (*LCD upon request*)
- Meas. range: 900...1050 hPa
- Accuracy: ± 1 hPa at 20°C
- Operating temperature: $0...50^\circ\text{C}$
- Power supply: 13...28 V DC; 24 V AC ± 10 %
- Dimensions: 144 x 144 x 64 mm
- Weight: approx. 0.2 kg

Barotransmitter with digital display, output 0...5 V **X005.100M**

Barotransmitter with digital display, output 4...20 mA **X005.200M**



5012.0000

Barograph

with aged aneroid capsule unit as measuring element. Temperature compensated for -25...+50°C. Clockwork can be set to daily or weekly rotation. Also available with **oil damping** for naval applications. Further available: quartz drive, for operating temperatures down to -35°C.

Measuring range: 950...1050 hPa
 Accuracy: ± 0.5 hPa
 Type 5012: Dimensions: 290 x 145 x 190 mm; Weight: 2.5 kg
 Type 5014: Dimensions: 345 x 170 x 180 mm; Weight: 3.5 kg
 Type 5016: Dimensions: 245 x 140 x 175 mm; Weight: 3.2 kg

Type No.



5016.2200

Barograph

in metal housing
 in wooden housing
 As above, with oil damping
 with acrylic glass hood and mahogany socket
 As above, with oil damping

X012.000M
X014.000M
X014.200M
X016.020M
X016.220M



Precision Aneroid Barometer with DHI (BSH) Certificate

with aged aneroid capsule unit as measuring element. Temperature compensated for -30...+40°C. Metal housing with mounting flange and chrome-plated fronting. Also available in wooden case.

Measuring range: 900...1060 hPa
 680...800 mm Hg
 Division: 1/1 hPa
 1/1 mm Hg
 Accuracy: ± 0.7 hPa, ± 0.5 mm Hg
 Dimensions: max. Ø 160 mm
 Weight: approx. 0.5 kg

As 5020, but with **pressure tight housing**
 As above, with labyrinth and connection hose
 As 5020, built in wooden case

X020.000M
X021.0000M
X021.1000M
X022.000M

Hg-Station Barometer

Cistern barometer with reduced scale. Simple operation with gear operated vernier adjustment. With attached thermometer. Lacquered respectively nickel plated surface. Glass tube with 8 mm internal diameter. Supplied in a wooden carrying case. Also available as test barometer for connection with pressure/vacuum chambers.

Measuring range: 800...1080 hPa
 respect. 560...1030 hPa
 Division: 1/1 hPa (basic scale)
 0.1 hPa (by vernier)
 Thermometer range: -5...+50°C
 Dimensions, incl. carrying case: approx. 1200 x 150 x 100 mm
 (L x W x H)
 Weight, incl. carrying case: approx. 7 kg

Hg-Station Barometer
 Range 800...1080 hPa
 Hg-Station and Test Barometer
 Range 560...1030 hPa
 with manufacturer's calibration certificate
 with official calibration certificate

X110.200M
X110.300M

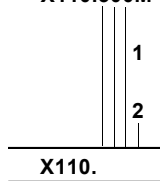

X110.



Barometer support, illuminated, as well as test chambers (Rezipients) and accessories for the calibration of barometers refer to product group 8

Type No.

Si-Global Radiation Sensor

measures the global radiation, basing on a silicon diode with diffusor and PMMA-dome. Especially suitable as reference for photovoltaic systems, including built-in measuring amplifier.



| | | |
|----------------------|---------------------------|------------------|
| Spectral range: | equals silicon | |
| max. sensitivity at: | 780 nm | |
| Meas. range: | 0...1300 Wm ⁻² | |
| Operating temp.: | -20...+60°C | |
| Linearity: | < 1% | |
| Absolute error: | < 10 % | |
| Power supply: | 9... 30 V DC | Output: |
| Output: | 0...5 V | 0...5 V |
| | resp. 4...20 mA | 4...20 mA |
| Dimensions: | Ø 42 x 70 mm, cable 1.5 m | X003.100M |
| Weight: | approx. 0.10 kg | X003.200M |

Si-Global Radiation Sensor

measures the global radiation, basing on a silicon diode, with diffusor above. Especially suitable for photovoltaic systems, incl. mounting plate.

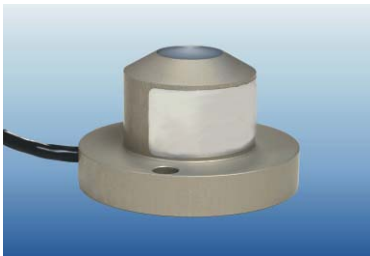

| | | |
|------------------------|---------------------------|------------------|
| Spectral range: | equals silicon | |
| Sensitivity (nominal): | 100 µV/Wm ⁻² | |
| Response time: | < 1 s | |
| Measuring range: | 0...2000 Wm ⁻² | |
| Operating temp.: | -30...+70°C | |
| Temp. coefficient: | ±0.15 %/K | |
| Cosine error ≤ 80°C: | < 10 % | |
| Spectral range: | 0.4...1.1 µm | |
| Dimensions : | Ø 54 x 34 mm, cable 3 m | |
| Weight: | approx. 0.40 kg | X004.000M |

Pyranometer

measures the global radiation, ranging 0.3...3 µm wave length. This instrument is classified in accordance with WMO (ISO 9060) class 2 and consists of a blackened receiver plate, connected to a thermopile, precision glass dome cover and anodized aluminium housing.

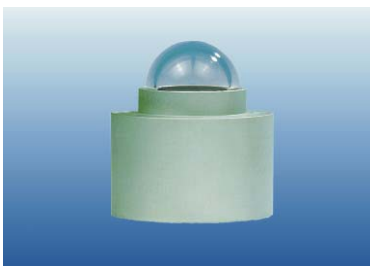

| | | |
|--------------------|--|------------------|
| Spectral range: | 305...2800 nm | |
| Sensitivity: | 10...35 µV/Wm ⁻² , indiv. calibration | |
| Impedance: | 79...200 Ω | |
| Response time: | 18 s for 95 % | |
| Linearity: | ±2.5 % (< 1000 Wm ⁻²) | |
| Tilt error: | < ±2 % | |
| Operating temp.: | -40...+80°C | |
| Temp. dependence: | 6 % (-10...+40°C) | |
| Directional error: | < ±25 Wm ⁻² at 1000 Wm ⁻² | |
| Dimensions/Weight: | Ø 54 x 60 mm / approx. 0.35 kg, cable 5 m | X005.000M |

Pyranometer

measures the global radiation, ranging 0.3...3 µm wave length. The instrument is classified in accordance with WMO (ISO 9060) class 1 and consists of a cylindrically shaped anodized aluminium body with built-in 64 element-thermopile and double glass domes. A white protection screen prevents the body from being heated up by radiation. A spirit level and 3 set screws enable an exact alignment. Easy accessible desiccant cartridge.



| | | |
|--------------------|---|------------------|
| Spectral range: | 305...2800 nm | |
| Sensitivity: | 9...15 µV/Wm ⁻² , indiv. calibration | |
| Impedance: | 70...100 Ω | |
| Response time: | 1-1/e: 5 s; 99 %: 55 s | |
| Linearity: | < 1.5 % (< 1000 Wm ⁻²) | |
| Tilt error: | < 1.5 % at 1000 Wm ⁻² | |
| Operating temp.: | -40...+80°C | |
| Temp. dependence: | ±2 % (-10...+40°C) | |
| Max. irradiance: | 2000 Wm ⁻² | |
| Directional error: | < ±20 Wm ⁻² at 1000 Wm ⁻² | |
| Dimensions/Weight: | Ø 150 x 92 mm / approx. 0.85 kg, cable 10 m | X012.000M |

Type No.

Pyranometer

X013.000M

as type X012, but with enhanced features for application as reference device in accordance to WMO - classification "Secondary Standard".

| | | | |
|-----------------|---|--------------------|---|
| Spectral range: | 305...2800 nm | Tilting error: | $\pm 0.25\%$ at 1000 Wm^{-2} |
| Sensitivity: | $4...6 \mu\text{V/Wm}^{-2}$, indiv. calibration | Operating temp.: | $-40...+80^\circ\text{C}$ |
| Impedance: | 700...1500 Ω | Temp. dependence: | $\pm 1\%$ ($-10...+40^\circ\text{C}$) |
| Response time: | 12 s for 95 % | max. irradiance: | 4000 Wm^{-2} |
| Linearity: | $< 0.6\%$ ($< 1000 \text{ Wm}^{-2}$) | Directional error: | $< \pm 10 \text{ Wm}^{-2}$ at 1000 Wm^{-2} |
| | | Dimensions/Weight: | $\varnothing 150 \times 92 \text{ mm}$ / approx. 0.85 kg, cable 10 m |

PAR Sensor

X017.000M



The sensor measures radiation within the photosynthetic relevant spectrum. The sensitivity corresponds the optimum efficiency of chlorophyll. The measuring results enable a reliable assessment of development conditions of plants.

| | |
|-----------------------|---|
| Meas. range: | 0...approx. 250 Wm^{-2} |
| Spectral sensitivity: | 380...700 nm |
| Sensitivity-max. at: | 420 nm and 600 nm |
| Operating temp.: | $-20^\circ\text{C}...+60^\circ\text{C}$ |
| Output: | 0...5 V or 0/4...20 mA |
| Power supply: | +9...+30 V DC |
| Diffusor: | PTFE |
| Dome: | PMMA (UV- pervious) |
| Cosine-correction : | error $f_2 < 3\%$ |
| Linearity: | $< 1\%$ |
| Absolute error: | $< 12\%$ |
| Offset (E=0): | $< 20 \text{ mV}$ |
| Dimensions: | $\varnothing 42 \times 70 \text{ mm}$ |
| Weight: | approx. 0.10 kg |

PAR Sensor

X018.000M



as type X017, but with enhanced optical features suitable for demanding scientific requirements.

| | |
|-----------------------|---------------------------------------|
| Meas. range global: | 0...approx. 250 Wm^{-2} |
| Spectral sensitivity: | 380...700 nm |
| Sensitivity-max. at: | 420 nm and 600 nm |
| Operating temp.: | $-20...+60^\circ\text{C}$ |
| Output: | 0...5 V or 0/4...20 mA |
| Power supply: | +9...+30 V DC |
| Diffusor: | PTFE |
| Dome: | optical glas |
| Cosine-correction : | error $f_2 < 3\%$ |
| Linearity: | $< 1\%$ |
| Absolute error: | $< 10\%$ |
| Offset (E=0): | $< 10 \text{ mV}$ |
| Dimensions: | $\varnothing 80 \times 82 \text{ mm}$ |
| Weight: | approx. 0.30 kg |

Types:

| | | |
|----------|-------------------------|------------------|
| Options: | with mounting plate | X018.100M |
| | with ventilation device | X018.200M |

Radiation Balance Meter

X020.000M

WMO, class 1, to measure the difference between incident radiation and reflected radiation at a short and long spectral range. The black lacquered copper plates at both sides are connected to thermopiles measuring the temperature of the differentially heated plates and thus forming the difference. Protection by "Lupolen" domes which are pervious for radiation in the mentioned spectral range. Supplied with fastening bracket, desiccant vessel and box levels.

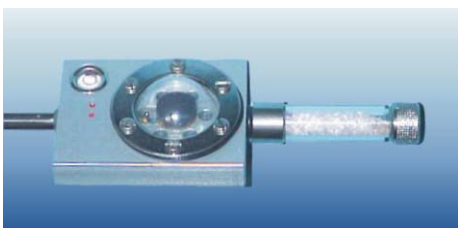

| | |
|--------------------|---|
| Spectral range: | 0.3...60 μm |
| Sensitivity: | approx. $9 \mu\text{V/Wm}^{-2}$, indiv. cal. |
| Measuring range: | approx. 1050 Wm^{-2} max., indiv. cal. |
| Impedance: | approx. 5Ω |
| Response time: | approx. 20 s for 95 % FS |
| Operating temp.: | $-40...+60^\circ\text{C}$ |
| Connection cable: | approx. 3 m |
| Fastening: | stainl. steel rod $\varnothing 8 \text{ mm}$, L=400 mm |
| Dimensions/Weight: | $520 \times 50 \times 30 \text{ mm}$ / approx 0.35 kg |

Type No.

Net radiometer

X024.000M

with integrated Pt 100 temperature sensor and 12 V heating



The net radiometer is suitable particularly for analysing the short and long wave net radiation.

The device consists:

Four separate detectors with equal sensitivity.

A rugged and weatherproof housing

Built-in heating element

Built-in Pt 100 temperature probe

Application:

Agrometeorology: Investigation of Evapotranspiration

Climatology: Investigation of net radiation

Building structure research: Measurement of thermal load

Solar energy: Investigation of heat exchange at thermal solar systems

Permanent road monitoring

Prevention of crop damage

Special features :

All 4 sensors have equal sensitivity

Pt 100 in acc. to DIN, class A

Heating resistor 24 Ω , 6 W at 12 V

Response time:

short wave:

long wave:

18 s

18 s

Adjust. error:

< 25 W/m²

n. a.

Spectral range:

305...2800 nm

5000...50.000 nm

Expected output under atmospheric conditions:

0...50 mV

-25...+25 mV

Operating temp.:

-40...+70°

Expected accuracy of the daily total values:

± 10 %

Length of cable:

10 m

Weight:

4 kg

Suitable data acquisition devices :

For net radiation, only: one mV - channel

For all four components: four mV - channels, one Pt 100 channel incl. software

Pyrgeometer

X027.000M

for measuring the radiation intensity in the far infrared range



Spectral range:

5...50 μ m

Viewing angle:

150°

Sensitivity:

10...20 μ V/Wm⁻²

Impedance:

125 Ω

Operating temp.:

-30...+40°C

Range:

-250...+250 Wm⁻² (V/C)

Temperature measurement

Pt 100

Heating:

12 or 24 V, 1 W

Dimensions/weight:

Ø 150 x 73 mm, approx. 0.85 kg, cable 10 m

UV Radiometer

X028.000M

for wide range measurement of UV-A and UV-B radiation intensity



Spectral range:

300...400 nm nominal

Side band elimination:

10⁻⁶ (400-3000 nm)

Cosine-error:

< 10 %

Azimuth-error:

< 10 %

Output impedance

10 k Ω (nominal)

Temp. dependence:

± 0.1% K max.

Sensitivity at 365 nm:

500 μ V/Wm⁻² (nominal)

Range of signal:

0...100 mV

Range of signal for atmospheric conditions:

0...40 mV

Operating temp.:

-20...+50°C

Offset:

< 0.05 mV

Dimensions/weight:

Ø 150 x 92 mm, approx. 0.85 kg, cable 10 m

Type No.

Light Sensor

X035.000M

for measurement of illumination, ranging 0...100000 lx. The device with voltage output requires no external supply, versions with optional built-in amplifier, e.g. 4...20 mA, upon request.

| | | | |
|------------------------|------------------|----------------------|-----------------|
| Sensing element: | special Si diode | Long term stability: | < ±2 %/a |
| Measuring range: | 0...100 klx | Response time: | < 5 ms |
| Output: | 0...10 mV | Temp. coefficient: | < 0.2 %/K |
| Basic accuracy: | ±7 % | Operating temp.: | -30...+60°C |
| Non-linearity: | ±3 % | Connection cable: | approx. 3 m |
| Azimuth error: | ±4 % | Dimensions: | 82 x 59 x 68 mm |
| Receiving angle error: | ±5 % | Weight: | approx. 0.40 kg |

Electronical Sunshine Duration Sensor

X038.000M

for sunshine duration measurement, whereby sunshine is defined $\geq 120 \text{ Wm}^{-2}$ in accordance with WMO standards. Additional analog output for the actual value of direct radiation. The device operates without moving parts, the built-in heating features 2 levels.



| | |
|------------------|---|
| Measuring range: | 0...1000 Wm^{-2} |
| Sensitivity: | 1 Wm^{-2} = 1mV nominal |
| Accuracy: | traceable to World Radiometric Reference |
| Output: | Digital: 0 V = sun, no; 1 V = yes $\geq 120 \text{ Wm}^{-2}$ Analog: 0...1 V = 0...1000 Wm^{-2} |
| Operating temp.: | -30...+70°C |
| Power Supply: | 12 ± 3V DC, without heating < 10 mA, with heating level 1: 1 W; level 2: 10 W |
| Housing: | Aluminium, anodized |
| Fastening: | hole \varnothing 7 mm |
| Dimensions: | 306 x 131 x 72.5 mm |
| Cable length: | approx. 3 m |
| Weight: | approx. 1.00 kg |

Campbell-Stokes Sunshine Recorder

for recording the sunshine duration; black lacquered unit with clear glass dome; dome bracket can be aligned by means of a box level.



| | |
|---|--------------------|
| Following versions available: | |
| For equatorial zones 0...40° latitude N or S | |
| For Northern and Southern hemispheres 25...60° latitude | |
| Dimensions: | 205 x 180 x 250 mm |
| Weight: | approx. 5.30 kg |

X040.100M
X040.200M

All sensors of this product group can be directly connected to our datalogger (refer to product group 1). The logger's lowest voltage range is ±6.25 mV. With additional drift compensation, accuracies of ±3 µV are obtained.

External measuring converter 4...20 mA for radiation sensors: Refer to product group 1; type X130.000M



7011

Rain Gauge

consisting of a collecting funnel, protective housing with rain cover, built-in measuring vessel with float and syphoning device. Recording on a clockwork driven drum; nominal recording period 7 days; recording height 80 mm, recording chart width for 10 mm rain divided into 1/10 mm.

| | | | |
|------------------|-------------------------|---------------|---------------|
| Measuring range: | 0...10 mm precipitation | Total height: | 1000 mm |
| Orifice: | 200 cm ² | Weight: | approx. 14 kg |
| Resolution: | 0.1 mm | | |

as above, with built-in heating 42 V / 250 W, controlled by thermostat incl. power supply

Rain Gauge

Similar to type X011, but with line recorder instead of drum recording; nominal recording period 31 days, recording chart divided into 1/10 mm.
Weight: approx. 18 kg.

With built-in heating 42 V/250 W
Feed: 10 mm/h
Feed: 20 mm/h

Type No.

X011.000M

X011.100M

X013.000M

100M

10M

20M

X013.



Rain Gauge, Small Version

consisting of upper and lower housing part, measuring cylinder, housing made of stainless steel, orifice rim made of brass.

| | |
|---------------------|---------------------------------------|
| Orifice: | 100 cm ² |
| Measuring cylinder: | 250 cm ³ ; 1/1 mm division |
| Dimensions: | Ø 115 mm; height 300 mm |
| Weight: | approx. 0.8 kg |

X019.000M



Rain Gauge

German Meteorological Service design, consisting of collecting part and lower part made of stainless steel, collecting can and fastening device.

| | |
|---------------------|---|
| Orifice: | 200 cm ² |
| Measuring cylinder: | 0...10 mm precipitation; 0.1 mm division |
| Collecting can: | 1.2 l |
| Dimensions: | Ø 181 mm; height 440 mm |
| Weight: | approx. 3.5 kg |

Rain Gauge

As above, as **Rain- and Snow Gauge**
with 2 lower parts, 2 collecting cans and
2 snow crosses and one cover lid

X021.000M

X021.200M



Precipitation Detector

for optical detection of precipitation (yes/no output) with built-in heating for winter condition.

| | |
|-------------------|--|
| Sensing orifice: | 25 cm ² |
| Particle size: | ≥ 0.3 mm |
| Power supply: | 24 V AC/DC ± 15 %, 70 mA without heating, max. 1 A with heating |
| Output: | Precipitation, yes = contact open Precipitation, no = contact closed Contact load max 230 V AC, 4 A; Switching conditions: 2 bis 15 drops within 50 s |
| Operating temp.: | -25...+55°C |
| Protection class: | IP 65 |
| Dimensions: | 130 x 140 x 40 mm |
| Weight: | approx. 0.4 kg |

X030.000M

Type No.

Precipitation Pulse Transmitter



Tipping bucket system. Housing made of black ABS. Available with optional heating, thermostat controlled, for winter conditions. Also available with battery-supplied built-in datalogger.

| | | | |
|-------------------------|--|---|--------------------------------------|
| Orifice: | approx. 200 cm ² | Precipitation sensor with Reed contact | |
| Bucket content: | 4 cm ³ resp. 2 cm ³ | resolution 0.2 mm | X041.000M |
| Resolution: | 0.2 mm precipitation resp. 0.1 mm precipitation | as above, incl. datalogger | X041.010M |
| Measuring range: | 0...15 mm/min intensity | Resolution 0.2 mm with built-in heating | X041.100M |
| Accuracy: | ± 5 % | as above, with datalogger | X041.110M |
| Supply voltage: | 12 VDC, Heating 24 VAC | Resolution 0.1 mm as above, with datalogger | X041.200M X041.210M |
| Output: | Reed switch | | |
| Heating (type -.1,-.3): | 24 V / 24 W, thermostat controlled | Resolution 0.1 mm with built-in heating | X041.300M |
| Dimensions: | Ø 165 x 241 mm, | as above, with datalogger | X041.310M |
| Weight: | approx. 1.3 kg | Configuration- and read-out software for precipitation datalogger | X032.000M |
| Connecting cable: | 10 m (non heated versions; heated versions with terminal bar instead of cable) | Interface cable RS 232 for read-out the precipitation datalogger | X032.100M |
| | | Power supply for type 7041.1--- and 7041.3--- | X732.000M |
| | | Pole for concrete foundation measuring height 1.0 m | X012.000M |

Precipitation Pulse Transmitter



The precipitation pulse transmitter type 7051 serves for measuring of amount and intensity of rain by using the tipping bucket rain gauge system. This instrument features an excellent linearity up to an intensity of 4 mm / min. The alternate version with built-in heating system also measures solid precipitation (snow, hail) within a temperature range down to -25°C. The orifice of this unit is 200 cm² and corresponds to the standards of the German Meteorological Service.

| | | | |
|------------------------|-------------------------------------|--|------------------|
| Orifice: | 200 cm ² | Precipitation sensor with reed contact | X051.000M |
| Content of bucket: | 2 cm ³ | As above, with built-in heating | X051.100M |
| Resolution: | 0.1 mm precipitation | | |
| Measuring range: | 0...15 mm/min | Power supply for type 7051.1000 | X731.000M |
| Accuracy: | ± 3 % up to 4 mm/min intensity | | |
| Operating temperature: | | Pole for concrete foundation, measuring height 1,0 m | X011.000M |
| Type 7051.0: | 0...+60°C | | |
| Type 7051.1: | -25...+60°C | | |
| Power supply: | 24 V AC; 150 VA (type 7051.1) | | |
| Output signal: | Reed contact; 0,5 A resp. 24 V max. | | |
| Heating power: | approx. 140 W (type 7051.1) | | |
| Connector: | plastic, 7-pole, IP 67 protected | | |
| Dimensions: | Ø 192 x 470 mm | | |
| Weight: | 4.1 kg | | |

Piché Evaporation Gauge

X058.000M

measuring tube closed at one end, with nickel-plated suspension eye and 100 blotting paper strips.

Type No.

X062.000M

Evaporation Measuring System



This measuring system, type X062 serves for measurement of evaporation over soil and plantation surfaces, in particular for agricultural and environmental applications. The measuring principle bases on a "Modified Bowen Ratio" (MBR) method, extended by air flow measurement close to the soil surface. For this purpose, two special Frankenger psychrometers and a 3D-sonic anemometer are used. A short adjustable aluminium mast with stainless steel guys serves as support. Data evaluation can be accomplished by means of a commercial size PC. A suitable software program is attached.

- Psychrometer: Type X010.400M (refer to group 3)
- Sonic Anemometer: Type X302.000M (refer to group 4)
- Output: Serial RS 232
- Supply: 24 V DC
- Operating temp.: 0...+60°C
- Dimensions: max. height: approx. 3.1 m, guy radius: approx. 2.0 m
- Weight: approx. 30 kg, compl.

Water Level Pressure Sensor



The sensor type X510 is designed to measure water level of lakes, rivers, reservoirs etc., as well as ground water level. The probe is normally installed in a tube, $\geq 2"$. The included clamping bracket, attached to the suspension cable, serves for adjustment of the measuring depth. The water level is measured by means of a ceramic differential pressure sensor, comparing the actual water pressure with the ambient air pressure. For this purpose the ambient air is linked to the sensor by means of a hose placed in the core of the suspension cable.

- Meas. ranges: 0...1 m to 0...250 m (specify with order)
- Genauigkeit: 0,25 % FS (type 7510.1000) resp. 0.10 % FS (type 7510.2000)
- Output: 4...20 mA, 2 line
- Power supply: 24 V DC
- Housing: Stainless steel, 1.4571
- Sensor: CERTEC Ceramic
- Suspension cable: PE, 12 m length (Standard); *other lengths up to 200m upon request*
- Clamping bracket: Stainless steel, 1.4305, max. \varnothing 52 mm
- Dimensions: \varnothing 32 x 181 mm length.
- Weight: approx. 1.50 kg

Water level sensor, class 0.25 % **X510.100M**

Water level sensor, class 0.1 % **X510.200M**

Calibration device, cable connection box and further accessories: upon request

Type No.

X520.000M



Water Level Radar Sensor

with horn antenna, for indirect measurement of water level of lakes, rivers, reservoirs etc. by determination of the distance between water level and a fixed sensor position above (e.g. at a bridge), using the principle of Radar reflection from the water surface. Continuous measurement by means of 26 GHz technology.

| | |
|-----------------|--|
| Meas. range: | 0.05...15 m (distance through air) <i>other ranges upon request</i> |
| Resolution: | max. 1 mm |
| Accuracy: | ± 3 mm within 0.5...15 m under reference conditions by IEC 60770-1 |
| Output: | 4...20 mA, 2 line |
| Meas. interval: | approx. 1 s |
| Power supply: | 24 V DC |
| Housing: | PBT (Polyester), <i>other materials upon request</i> |
| Antenna: | 18°; Ø 48 mm; stainless steel, 1.4435 |
| Fastening: | G 1 ½" thread |
| Dimensions: | Length: 292 mm, max. width: 107 mm |
| Weight: | approx. 2.50 kg |

Display module and calibration accessories upon request



Water Level Sensor with built-in Datalogger

X530.000M

consisting of a pressure sensor, similar to type X510, with integrated datalogger and a Li – battery built-in a special plastic probe housing. An additional built-in NTC – temperature sensor enables continuous measurement and storage of water temperature data.

The probe is normally installed in a tube, ? 2". The included clamping bracket, attached to the suspension cable, serves for adjustment of the measuring depth. The suspension cable also features to link the ambient air to the sensor by means of a hose placed in the core of the cable.

A readout software is included.

| | |
|-------------------|--|
| Meas. range: | Water level: 10 m resp. 20 m (specify with order) Water temperature: –5...+45°C |
| Accuracy: | Water level: 0.10 % FS Water temperature: ± 0.1 K |
| Data acquisition: | Datalogger with memory for 10 000 meas. values (circulate memory), real time clock, serial interface RS232 |
| Power supply: | Li – battery; life time depending on scan rate, e.g. with 1h – scan rate, approx. 10 years |
| Dimensions: | Ø 46 x 350 mm (housing) |
| Weight: | approx. 1.20 kg |
| Cable length: | 10 m; <i>other lengths on request</i> |

Type No.



Thermometer Test Equipment

consists of thermometer test bath incl. electronic temperature control, continuous cooler, special lamp and a set of standard thermometers.

Thermometer Test Bath with double safety glass pane; very easy reading of the test and control thermometers; adjustable frame for installation of different thermometer sizes; flow regulation by means of a circulating pump; cooling coils for external connection, e. g. of a cryomat, built-in electrical temperature control device with resistance thermometer.

X100.000M
X101.000M

Type X100.000M

Bath volume: approx. 23 l
Front pane: 340 x 340 mm
Meas. range: -20°C...+50°C with cooler type 8105
Power supply: 230 VAC, 50 Hz, approx. 3 kVA
Heating power: 400...2700 W
Dimensions: 800 x 230 x 670 mm
Weight: approx. 42 kg
Electronic temperature control: by Pt 100, PID controller, LED display. Temperature setting with 0.01°C resolution

Type X101.000M

approx. 33 l
540 x 340 mm
-10°C...+50°C with cooler type 8105
230 VAC, 50 Hz, approx. 3 kVA
400...2700 W
1160 x 230 x 670 mm
approx. 49 kg

Bath liquids

Depending on the individual application, two different kinds of bath liquid are available (silicon fluid for example, in connection with an external cryomat).

Water-glycol solution (down to -20°C)
Silicon fluid (down to -40°C)

X104.100M
X104.300M

The **Continuous Cooler** is maintenance-free refrigerator engine with heat exchanger; connection to the circulation pump of the test bath features an intensive continuous cooling.

Refrigeration power: 0.33 kW at 20°C
Power supply: 230 VAC, 50 Hz
Dimensions: 290 x 540 x 330 mm
Weight: approx. 33 kg

X105.000M

Refrigerator thermostats, cryostats etc. for lower bath temperatures

Upon request

The **Special Lamp** is suitable to illuminate the test bath; it produces a light similar to daylight and free of heat radiation.

Special lamp for type 8100:
Special lamp for type 8101:

X114.000M
X115.000M

The **Control Thermometers** (1 set = 2 thermometers).

Meas. range: -38°C...+10°C; - 1°C...+51°C

Set of control thermometers, with manufacturer's calibration certificate

X117.00M1

Scaling: 0.1°C

Set of control thermometers, with official calibration certificate

X117.00M2



Temperature Test Cabinet

Light grey varnished housing with illuminated stainless steel test chamber, compl. with racks and safety glass pane in frontdoor. Suitable for simultaneous test of 4 thermographs respectively 2 thermohygrographs, or similar instruments. Temperature setting via keyboard and LED display on the front panel.

Meas. range: -40°C...+180°
Test chamber volume: approx. 100 l
Power supply: 230 VAC, 50 Hz, approx. 2.4 kW
Dimensions: 1670 x 820 x 840 mm (H x W x D)
Weight: approx. 230 kg

X121.000M

Further sizes and temp. ranges upon request!

Climatic Cabinets

Different sizes as well as different specifications

Upon request

Meyer Industrie-Electronic GmbH – MEYLE

Carl-Bosch-Straße 8 Tel.: +49 54 81-93 85-0 Internet: www.meyle.de
49525 Lengerich/Germany Fax: +49 54 81-93 85-12 E-Mail: sales@meyle.de

Type No.



Windtunnel

The windtunnel type X420 is basically designed as test equipment for calibration of wind sensors.

The open construction with the measuring section in the suction part enables compact dimensions and therefore operation in relatively small rooms.

An SCR controlled DC motor drive enables a wide operation range and stable rotational speed.

Depending on customer's specification different reference equipment (Differential pressure gauges, Thermal anemometers as well as Laser-Doppler Anemometers) and accessories (Test adapters, PC's, Printers, Monitors etc.) are available. Custom made software solutions for semi- or fully- automatic operation incl. print out of final test reports can be offered.

| | |
|--|---|
| Meas. range: | 0.15...50 m/s |
| According Reynolds number: | $0.65 \times 10^4 \dots 2.15 \times 10^6$ (at $p_a=1013 \text{ hPa}$ und $t_a=20^\circ\text{C}$) |
| Degree of turbulence: (measured in tunnel cross section with resolution 0.5 Hz) | at $v= 3 \text{ m/s}: \pm 0.4 \%$ at $v=10 \text{ m/s}: \pm 0.4 \%$ at $v=40 \text{ m/s}: \pm 0.3 \%$ |
| Drive power: | approx. 40 kW |
| Drive control: | SCR |
| Power supply: | 230/400 VAC, 50 Hz /3Ph, max. 50 kVA |
| Dimensions: | 6115 x 2090 x 1565 mm (L x W x H) |
| Weight: | |
| Windtunnel incl. drive: | approx. 1400 kg |
| Control cabinet: | approx. 245 kg |

X420.000M

Example of numerical and graphical schemes of an anemometer characteristic

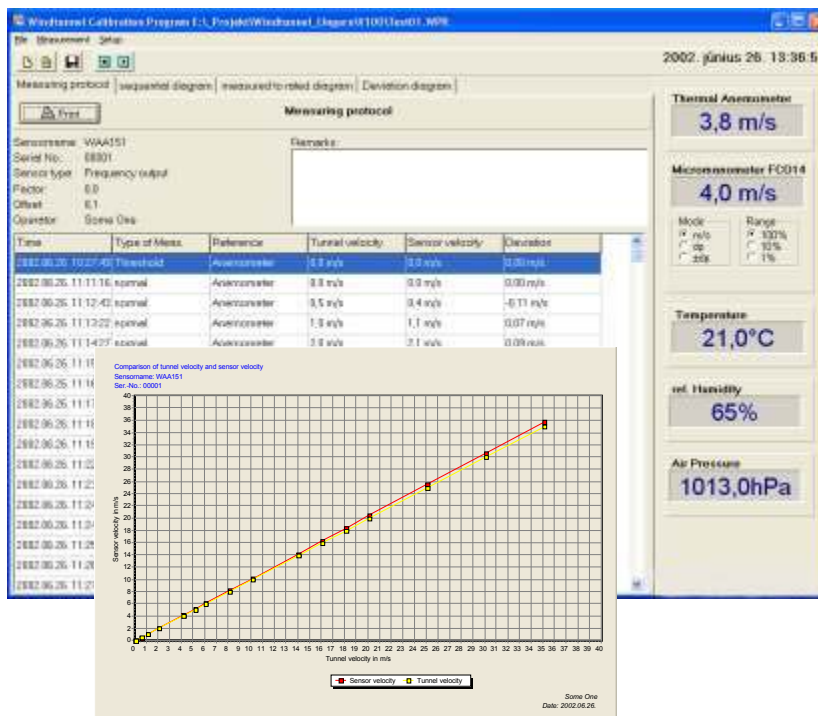

Type No.



Pressure / Vacuum Chamber

Pressure/vacuum chamber for testing several aneroids, barotransmitters, barographs, mercury barometers (with hood, type 8701); test chamber consists of cylindrical steel body, coated, with flange covered by a steel plate (or hood 8701) and sealed by means of an O-ring; a large inspection pane in the door made of 40 mm acrylic glass; built-in vibrating table with rung stand, actuated by push-button from outside; on the right 8 electrical ducts, on the left two air ducts NW 10 for connection to Hg-test barometer or other external units; operating valves at the front.

Recommended accessories: Hood, type 8701, cabinet, type 8720 to install the pump, support for test barometer, type 8740, control panel for vernier adjustment, type 8741.1, control motor type 8742, vacuum pump type 8750. Test barometers, refer to group 5.

Operating range: 100...1100 hPa, *other ranges upon request*
 Dimensions: 1150 x 850 x 830 mm, Weight: approx. 255 kg
 Required area: 770 x 520 mm
 Volume of test chamber: 234 l

X700.000M

Acrylic Glass Hood

For testing up to 4 mercury barometers; to replace the steel plate of type 8700; made of 40 mm acrylic glass.

Dimensions: 400 x 500 x 200 mm, Weight: approx. 28 kg

X701.000M



Pressure / Vacuum Chamber, small size

Pressure/vacuum chamber for testing aneroids, barotransmitters, barographs and a mercury barometer (with hood type 8711); test chamber made of a rugged steel construction, upper flange covered by an aluminium plate (or hood type 8711) and sealed by means of an O-ring. Door to be closed by 4 hand wheels, inspection pane in the door made of 30 mm acrylic glass; on the right electrical ducts, on the left 2 air ducts NW 10 for connection of Hg-test barometer or other external units; operating valves at the front.

Recommended accessories: Hood, type 8711, cabinet, type 8720 or base plate type 8721, to install the pump, electrical ducts etc., support for test barometer, type 8740, control panel for vernier adjustment, type 8741.1, control motor type 8742, vacuum pump type 8750 or 8760. Test barometers, refer to group 5.

Operating range: 700...1100 hPa, *other ranges upon request*
 Dimensions: 760 x 560 x 750 mm, Weight: approx. 107 kg
 Required area: 760 x 520 mm
 Volume of test chamber: 65 l

X710.000M

Acrylic Glass Hood

for type 8710 for testing one mercury barometer.

Dimensions: Ø 270 mm, 800 mm height,
 Weight: approx. 5.5 kg

X711.000M

Vibrating Table for pressure chamber type X710

X712.000M

Cabinet for Pressure / Vacuum Chamber

Sheet steel construction with wooden top plate and lockable front door; serves for installing test chambers 8700 or 8710 and test barometer support type 8740. Suitable for containing the pressure/vacuum pump.

Dimensions: 710 x 1000 x 700 mm (H x W x D), Weight: approx. 55 kg

X720.000M

Base Plate serves as a base for pressure chamber 8710 incl. accessories.

Dimensions: 900 x 600 x 19 mm Weight: approx. 6.3 kg

X721.000M

Support for Test Barometer

Plastic coated wooden construction; background illumination by means of a fluorescent lamp.

Power supply: 230 VAC 50 Hz Dimensions: 1300 x 170 x 120 mm Weight: approx. 7 kg

X740.000M

Test barometers, refer to product group 5

Type No.

Control Panel for Remote Vernier Control

to operate control motors type 8742 or 8744, with built-in power supply and push buttons for remote operating of the vernier displacement.

| | | | |
|---------------|--------------------|--|------------------|
| Power supply: | 230 VAC 50 Hz | Control panel for 1 control motor | X741.000M |
| Dimensions: | 265 x 170 x 120 mm | Control panel for up to 4 control motors | X741.100M |
| Weight: | 0.9 kg / 1.8 kg | | |

Control Motor

X742.000M

for vernier control, consisting of U-shaped fastening bracket, guiding brackets and a DC gear motor, coupled to a receptacle which is screwed to the knurled vernier adjustment knob of the barometer on test.

| | | | | | |
|---------------|--------------------|-------------|------------------|---------|----------------|
| Power supply: | refer to type X741 | Dimensions: | 135 x 71 x 45 mm | Weight: | approx. 0.3 kg |
|---------------|--------------------|-------------|------------------|---------|----------------|

Control Unit for Fortin Barometers

for zero adjustment at the mercury vessel bottom.

| | | | |
|---------------|---------------------|--|------------------|
| Power supply: | refer to type X741 | Suitable for 1 Fortin barometer incl. adapter parts for pressure chamber type X700 | X744.000M |
| Dimensions: | Ø 85 mm, 60 mm high | as above, for 2 barometers | X744.100M |
| Weight: | approx. 0.3 kg | as above, for 3 barometers | X744.200M |
| | | as above, for 4 barometers | X744.300M |
| | | Control unit similar to X744.000M, but suitable for pressure chamber X710 | X745.000M |

Pressure/Vacuum Pump

X750.000M

Rotary vane pump for pressure chambers X700 or X710, equipped with relief valve and oil separator.

Double Piston Vibration Pump

X760.000M

Low noise pump without rotating parts, suitable for pressure chamber X710, range 700...1100 hPa.



Rain Gauge Test Equipment

X800.000M

for calibrating any kind of precipitation gauge; equipped with rotary pump and precision flow meter for exact simulation of rainfall intensity, with injector for static balancing of tipping bucket measuring systems and measuring cylinder to measure the reference water amount.

Frame made of anodized aluminium and PVC.

| | |
|------------------|--|
| Water pump: | rotary pump 0.44 kW, 2.2 A |
| Connection: | 230 VAC 50 Hz, via mains plug |
| Operating range: | up to 15 mm/min precipitation rate, related to 200 cm ² orifice |
| Dimensions: | 1900 x 600 x 500 mm (H x W x D) |
| Weight: | approx. 35 kg |



Sensor Test Unit

X820.000M

suitable for test of sensors listed in group 2...7. The individual configuration for each application depends on the layout of the complete meteorological system (on request, available in a sealed carrying case - see illustration).

Sensor Simulator

X821.000M

suitable for calibration of measuring converters or data acquisition systems (automatic weather stations). Simulation of all sensor functions listed in group 2...7 is possible. The individual configuration for each application depends on the layout of the complete meteorological system (on request, available in a sealed carrying case - see illustration).

Type No.

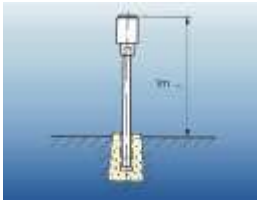

Pole, 1 m, self-supporting

made of aluminium alloy tube \varnothing 48 mm, to be embedded in a standard concrete foundation, suitable for installation of precipitation gauges.

Weight: approx. 1.50 kg

Suitable for precipitation gauge type X051:

X011.000M

(Foundation not included)

Suitable for precipitation gauge type X041:

X012.000M



Mast, 2 m, self-supporting

X020.000M

made of aluminium alloy tube \varnothing 48 mm, to be embedded in a standard concrete foundation; incl. crossarm to support max 3 sensors
(please state required types with the order).

Weight: approx. 6.40 kg

(Foundation not included)



Additional Crossarm

X021.000M

for masts \varnothing 48 mm; made of aluminium alloy tube \varnothing 35 mm, suitable to support 2 further sensors
(please state required types with the order)

Weight: approx. 2.80 kg



“Klemmfix”

X022.000M

Installation clamp for wind sensors type X0... resp. type X1..., to be mounted on crossarms. Internal \varnothing 33 mm. Made of anodized die-cast aluminium.

Weight: approx. 0.15 kg



Adapter

X023.000M

Installation socket for wind sensors type X0... resp. type X1..., to be mounted on vertical poles or masts. Internal \varnothing 48 mm. Made of aluminium alloy.

Weight: approx. 0.40 kg

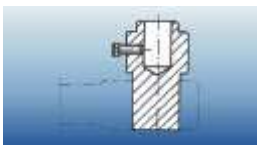

Adapter

X025.000M

Support for shelter type X120, to be used with crossarm type X021, resp. Klemmfix type 9022. Made of aluminium alloy.

Weight: approx. 0.23 kg

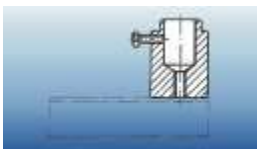

Adapter

X026.000M

Support for shelter type X120, to be used with crossarm type X111. Made of aluminium alloy.

Weight: approx. 0.20 kg

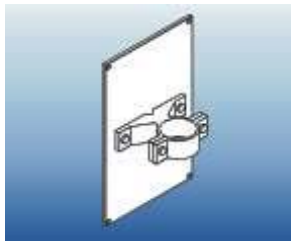

Type X028.3

Mast adapter

aluminium alloy with solid clamp resp. 2 zinc-plated snap-in clamps
 for cable box type X050.1
 for cable box type X050.2
 for cable box type X051.1 and X051.2
 for cable box type X051.3 and X051.4
 for power supply type X732
 for power supplies type X725.00M2, X726.00X2 resp. X73
 for 1 m- resp. 2 m-masts
 for 4 m- resp. 6 m-masts
 for 10 m-masts

Type No.

X028.100M
.200M
.300M
.400M
.500M
.600M
.10M
.20M
.30M

X028.

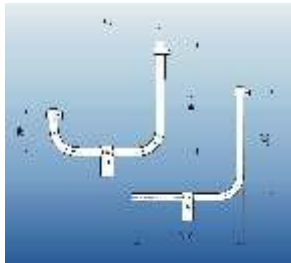

U-shaped Crossarm

to support one wind direction- and one wind speed sensor type X0../X1...
 Aluminium alloy tube Ø 40 mm. Socket-Ø 48 mm, internal.
 Dimensions in accordance with DWD-recommendation (see fig.).
Other dimensions upon request.
 Weight: approx. 1.80 kg

X040.000M

L-shaped Crossarm

as type X040, but in compact design with reduced horizontal arm
 Weight: approx. 1.4 kg

X040.100M

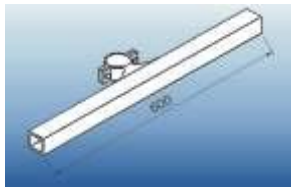

Crossarm

to support one wind direction- and one wind speed sensor type X091/X191.
 Square tube 40 x 40 mm, made of aluminium alloy. Incl. mast clamp Ø 48 mm.
 Dimensions: see fig.
 Weight: approx. 1.20 kg

X041.000M

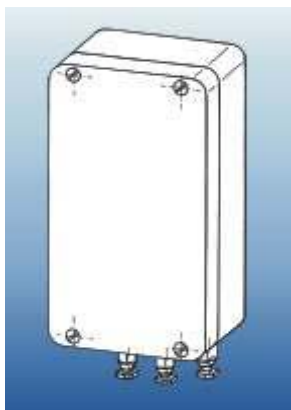

Cable box

for outdoor application, IP 65
 size approx. 80 x 175 x 57 mm, with 2 input and 1 output cable duct, equipped with 12 connection terminals
 Weight: approx. 0.80 kg
X050.100M
 size approx. 120 x 220 x 80 mm, with 4 input and 1 output cable duct, equipped with 30 connection terminals
 Weight: approx. 1.70 kg
X050.200M
 size approx. 160 x 260 x 90 mm, with 4 input and 1 output cable duct, equipped with 12 connection terminals
 Weight: approx. 2.35 kg
X051.100M
 size approx. 160 x 260 x 90 mm, with 4 input and 1 output cable duct, equipped with 20 connection terminals and 90 V overvoltage protection
 Weight: approx. 2.35 kg
X051.200M
 size approx. 160 x 360 x 90 mm, with 5 input and 2 output cable ducts, equipped with 30 connection terminals and 90 V overvoltage protection
 Weight: approx. 3.00 kg
X051.300M
 size approx. 160 x 360 x 90 mm, with 5 input and 2 output cable ducts, equipped with 40 connection terminals and 90 V overvoltage protection
 Weight: approx. 3.00 kg
X051.400M

Further overvoltage components upon request!

Type No.



Telescopic Mast

made of aluminium tubes incl. guys, base plate and earth pins; easy to transport. Suitable for installation of 2 wind sensors on a crossarm type X021 or type X040 resp. type X041, and additional sensors at measuring height 2 m.

Types X102 to X104: leight version
Types X105 to X106: Version for higher wind force

| | | | |
|-----------------------------------|----------------------|------------------------|------------------|
| Height above ground approx. 4 m, | tube weight 5.25 kg, | with 1 level of guys: | X102.000M |
| Height above ground approx. 6 m, | tube weight 6.5 kg, | with 1 level of guys: | X103.000M |
| Height above ground approx. 10 m, | tube weight 13.2 kg, | with 2 levels of guys: | X104.000M |
| Height above ground approx. 6 m, | tube weight 12.5 kg, | with 2 levels of guys: | X105.000M |
| Height above ground approx. 10 m, | tube weight 25.3 kg, | with 3 levels of guys: | X106.000M |

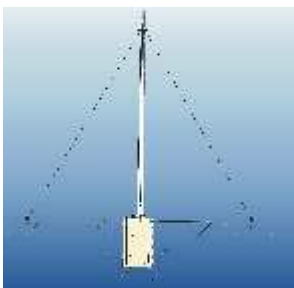

Tiltable Mast

made of conically drawn aluminium tubes, incl. guys, foundation bolts and guy anchors (foundation not included!)
Mast tube-Ø at the top: 60 mm (6 m mast) resp. 76 mm (10 m mast)

| | | |
|-------------------------------------|-------------------------------|------------------|
| Height: approx. 6 m | Weight, compl.: approx. 50 kg | X109.000M |
| Height: approx. 10 m; in 2 sections | Weight, compl.: approx. 73 kg | X110.000M |

Special versions with obstruction lighting and/or red/white finish acc. to ICAO upon request

Lattice masts, self-supporting from anodized aluminium or zinc plated steel upon request

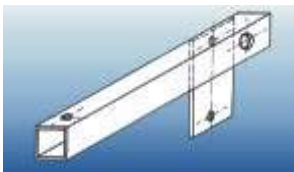

Crossarm

for 2 m - measuring height, for sensor installation (please state required types with the order). Square tube 50 x 50 mm, made of aluminium alloy.

| | | | |
|----------------------------|------------------------|-------------------------|------------------|
| Version, one-sided, | Length: approx. 500 mm | Weight: approx. 1.00 kg | X111.100M |
| Version, two-sided, | Length: approx. 900 mm | Weight: approx. 1.80 kg | .200M |
| for masts type X105 / X106 | | | .10M |
| for masts type X109 / X110 | | | .20M |

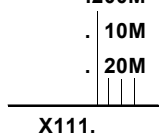

Lightning Rod

made of aluminium, incl. fastening clamps, suitable for sensor protection;

| | | |
|--|-------------------------|------------------|
| for plain crossarms type X021 and X041 | Weight: approx. 0.80 kg | X112.100M |
| for U-shaped crossarms type X040 | Weight: approx. 0.90 kg | X112.200M |
| for combined wind sensors type X4.. | Weight: approx. 0.50 kg | X112.300M |

Instrument shelter

wooden construction with white coating; walls and door with lamellar structure. Suitable for thermographs, hygrographs and similar instruments.

| | |
|--|------------------|
| Large DWD size | X200.000M |
| Weight: approx. 95 kg incl. support frame and step | |
| Small DWD size | X201.000M |
| Weight: approx. 15 kg | |



X200.000M

Overvoltage Protection

8 wires (without illustration); universal precision device optionally equipped with inductance or resistor, respectively Transil diode or varistor.

X710.000M

Type No.

Stainless Steel Housing

Protection class IP 65, with lockable handle; for installation of datalogger X020, as well as additional options (refer to ordering code).

Cable ducts down under. Solar panel (option X910.3000M) is attached by special support on the rear side.



Material: Stainless steel 1.4301; 1.5 mm
 Sealing: Expanded neoprene
 Protection class: IP 65
 Dimensions: approx. 240 x 240 x 150 mm (H x W x D)
 Weight: from 4.2 kg
 Mounting: Basic version: 4 lashings for M6 screws; distance 190 x 260 mm (W x H)
 Cable ducts: 16 pcs. PG 9, in 3 lines

Stainless steel housing IP 65 protected, with terminal bar for external supply

X910.100M

As above, but with 12 V battery supply

.200M

As above, but with 12 V battery supply, incl. controller and solar panel

.300M

with additional clamp for 2 m masts

. 10M

with additional clamp for 6 m masts

. 20M

with additional clamp for 10 m masts

. 30M

X910.

Sun protection roof

X911.000M

for stainless steel housing type X910



Housing, type X910.320M as part of an autonomous automatic weather stat

Custom made housings also in small quantities or as single systems can be delivered.