

Rotary Limit Switch RLS4C-LV



The rotary limit switch is used to control the movement of industrial machinery. It operates as an auxiliary controller of electrical motors through a power interface, such as a contactor or PLC. Suitable for heavy duty, its shaft is connected to the motor and, after a set number of revolutions, the cams operate the switches, thus starting the predetermined movement. A worm gear and a helical toothed gear combined with one or more pairs of straight toothed gears are used for the transmission of the movement from the input shaft to the output shaft.

Revolution ratios, ranging from 1:1 to 1:969, result from the use of different combinations of gear wheels between the input shaft and the output shaft, which is connected to the cams operating the switches.

Transmission and gear driving shafts are made of stainless steel to prevent oxidation and wear. The gear wheels and the driving bushes are made of self-lubricating thermoplastic material, suitably chosen to reduce the wear to a minimum and to maintain the accuracy of the couplings over time. Sintered bronze bushes are moulded into the base of the limit switch to optimise the shaft rotation and to prevent rubbing with plastic material.

Each cam can be set with great accuracy thanks to the cam adjusting screws. The auxiliary switches are of a positive opening type, thus suitable for safety functions. It is available with direct control switches for operating directly on the motor.

The cam-switch sets can be substituted for potentiometers suitable for the connection to electronic equipment. Each output of the limit switch can be set with a different revolution ratio to allow for a diversified control of the machinery to meet special requirements.

Materials and components are wear resistant and protect the equipment against water and dust. The limit switch is available with a flange for direct coupling to the motor and it can be customised with labels and colours according to the customer's requirements.

Technical Specifications

Conformity to Community Directives	73/23/CEE 93/68/CEE
Conformity to Standards	EN 60204-1 EN 60947-1 EN60947-5-1 EN 60529 EN 50013 IEC 536
Ambient temperature	Storage -40°C/+70°C Operational -25°C/+70°C
Protection degree	IP 65
Insulation category	Class II
Cable entry	Cable clamp M20

Technical Specifications of the Switches

Utilisation category	AC 15
Rated operational current	3 A
Rated operational voltage	36 V
Rated thermal current	10 A
Rated insulation voltage	300 V~
Mechanical life	1x10 ⁶ operations
Terminal referencing	According to EN 50013
Connections	Screw-type terminals with self-lifting pads

Standard Limit Switch Codes

Revolution ratio	Type of contact	2 switches	3 switches	4 switches
1:1	Snap	MY00010003LV	MY00010002LV	MY00010001LV
	Slow	MY00010004LV	MY00010005LV	MY00010006LV
1:5	Snap	MY00050002LV	MY00050003LV	MY00050001LV
	Slow	MY00050004LV	MY00050005LV	MY00050006LV
1:10	Snap	MY00100003LV	MY00100004LV	MY00100002LV
	Slow	MY00100005LV	MY00100006LV	MY00100007LV
1:15	Snap	MY00150004LV	MY00150003LV	MY00150002LV
	Slow	MY00150007LV	MY00150008LV	MY00150001LV
1:20	Snap	MY00200002LV	MY00200003LV	MY00200001LV
	Slow	MY00200004LV	MY00200005LV	MY00200006LV
1:25	Snap	MY00250006LV	MY00250003LV	MY00250001LV
	Slow	MY00250007LV	MY00250008LV	MY00250002LV
1:50	Snap	MY00500002LV	MY00500003LV	MY00500006LV
	Slow	MY00500028LV	MY00500017LV	MY00500007LV
1:75	Snap	MY00750007LV	MY00750008LV	MY00750004LV
	Slow	MY00750009LV	MY00750010LV	MY00750006LV
1:100	Snap	MY01000002LV	MY01000006LV	MY01000003LV
	Slow	MY01000001LV	MY01000013LV	MY01000004LV
1:150	Snap	MY01500002LV	MY01500011LV	MY01500008LV
	Slow	MY01500001LV	MY01500009LV	MY01500003LV
1:200	Snap	MY02000006LV	MY02000002LV	MY02000003LV
	Slow	MY02000007LV	MY02000004LV	MY02000008LV
1:250	Snap	MY02500003LV	MY02500007LV	MY02500008LV
	Slow	MY02500009LV	MY02500010LV	MY02500011LV
1:300	Snap	MY03000004LV	MY03000006LV	MY03000007LV
	Slow	MY03000008LV	MY03000009LV	MY03000010LV

Standard LV limit switches are equipped with 2,3 or 4 snap or slow action switches and with pointed cams MY140PI. Other assemblies and revolution ratios are available on request. It is possible to assemble up to 6 switches. Maximum revolution ratio 1:969.

Overall Dimensions

Standard Limit Switch

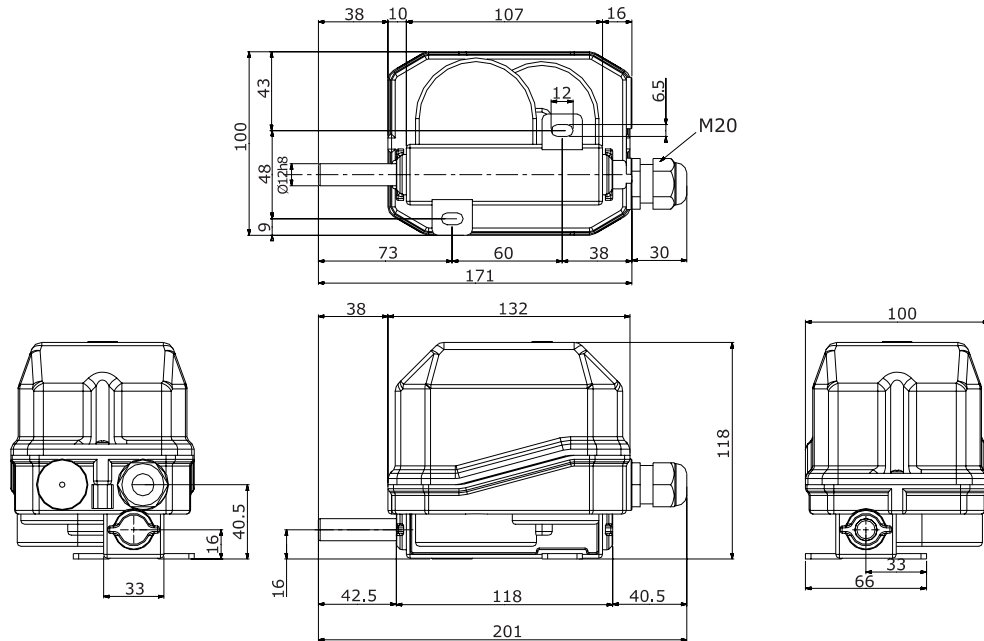



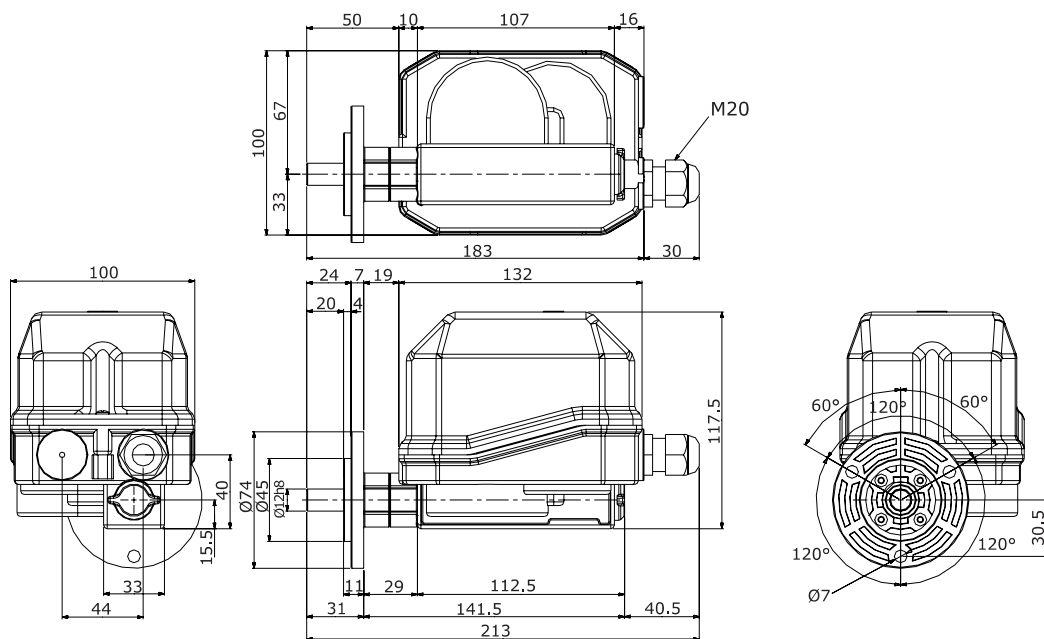



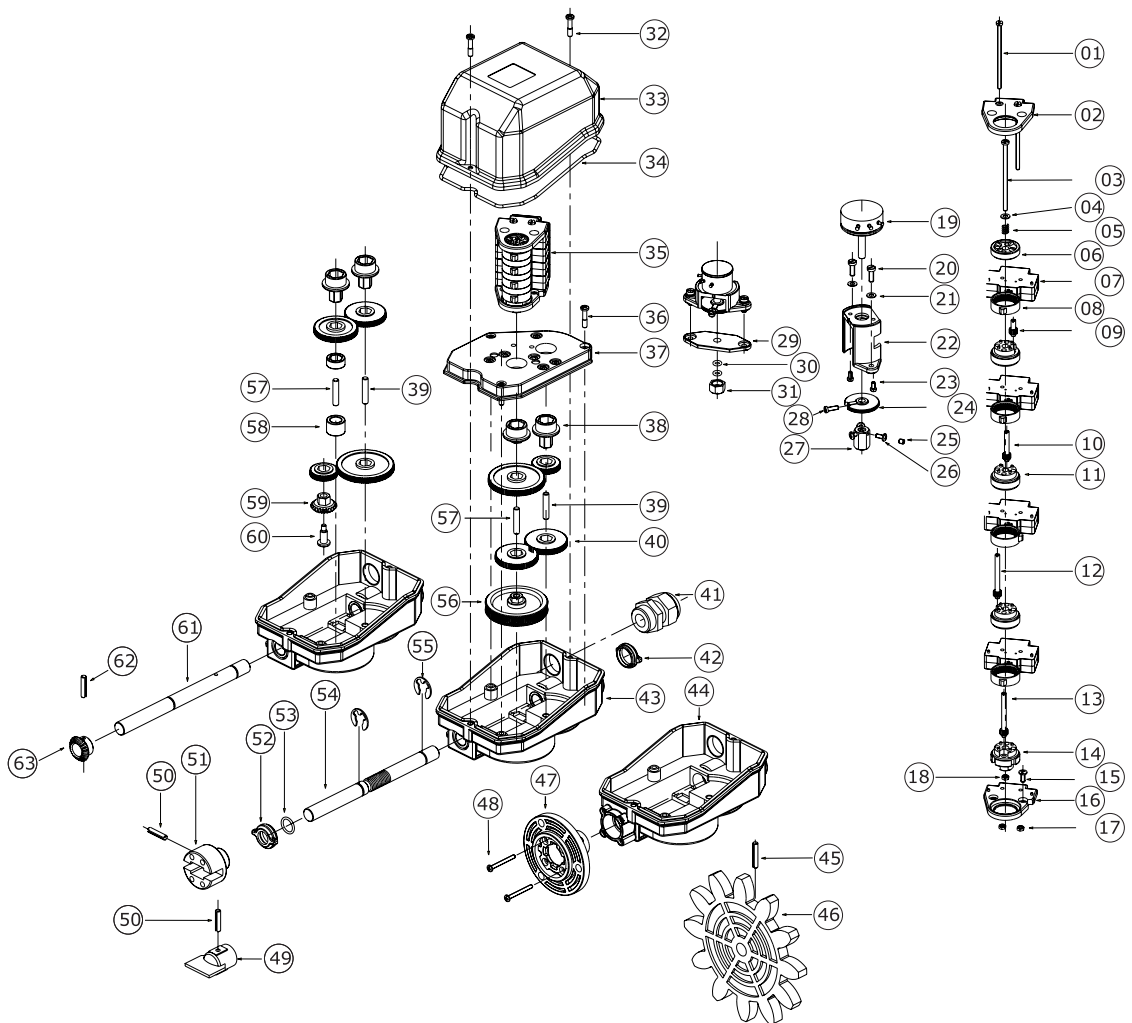





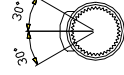
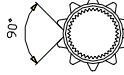
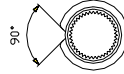

Limit Switch with Flange





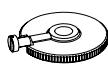

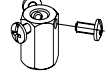
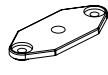

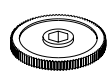
Detailed Drawing

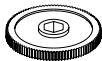
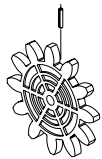
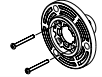

Parts List

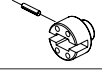
Reference	Drawing	Description
07		Snap action switch Slow action switch
08		Pointed cam
08		Sector cam
08		10 point cam
08		Circular cam
08		180° cam
19		Potentiometer 4.7 kW with continuous rotation Potentiometer 10 kW with continuous rotation Potentiometer 2.2 kW with continuous rotation
19		Potentiometer MCB 10 kΩ Potentiometer MCB 10 kΩ with continuous rotation
22 +20+21		Small support for potentiometer with O-ring
22 +20+21		Large support for potentiometer
22 +20+21		Medium support for potentiometer
22 +20+21		Medium support for potentiometer
24 +28		Adjusting gear
27 +26		Fixed coupling for potentiometer 33mm
27 +25		Fixed coupling for potentiometer 13mm
27 +26		Fixed coupling for potentiometer 17mm
29		Support plate for potentiometer with O-ring
31 +30		Bush for potentiometer
40		Lateral gear wheel Z 35 Lateral gear wheel Z 37 Lateral gear wheel Z 36 Lateral gear wheel Z 38 Lateral gear wheel Z 40

Parts List

Reference	Drawing	Description
40		Lateral gear wheel Z 42
		Lateral gear wheel Z 44
		Lateral gear wheel Z 46
		Lateral gear wheel Z 48
		Lateral gear wheel Z 50
		Lateral gear wheel Z 52
		Lateral gear wheel Z 54
		Lateral gear wheel Z 56
		Lateral gear wheel Z 58
		Lateral gear wheel Z 60
		Lateral gear wheel Z 62
		Lateral gear wheel Z 64
		Lateral gear wheel Z 66
		Lateral gear wheel Z 68
		Lateral gear wheel Z 70
		Lateral gear wheel Z 72
		Lateral gear wheel Z 74
		Lateral gear wheel Z 76
		Lateral gear wheel Z 78
		Lateral gear wheel Z 80
		Lateral gear wheel Z 82
		Lateral gear wheel Z 84
		Lateral gear wheel Z 86
		Lateral gear wheel Z 88
		Lateral gear wheel Z 90
		Lateral gear wheel Z 92
		Lateral gear wheel Z 94
Lateral gear wheel Z 96		
Lateral gear wheel Z 98		
Lateral gear wheel Z 100		
Lateral gear wheel Z 102		
Lateral gear wheel Z 104		
Lateral gear wheel Z 106		
Lateral gear wheel Z 108		
Lateral gear wheel Z 107		
Lateral gear wheel Z 109		
46 +45		Pinion gear M10 Z12
		Pinion gear M12 Z10
		Pinion gear M14 Z10
		Pinion gear M16 Z10
		Pinion gear M20 Z8
		Pinion gear M5 Z12
		Pinion gear M6 Z11
		Pinion gear M8 Z12
Pinion gear M12 Z12		
47 +48		Flange
49 +50		Male coupling
51 +50		Female coupling
54		Single-thread worm shaft
		Double-thread worm shaft
54		Flexible shaft
56		Central gear wheel Z 100

Request Form for Non Standard Limit Switches

Cams

- 1 MY140PI
- 2 MY141PI
- 3 MY142PI
- 4 MY143PI
- 5 MY144PI

Switches

- 1 MY036XXLV Snap action
- 2 MY037XXLV Slow action

Potentiometers / Encoders

- 1 MY020PE 4.7 k Ω continuous rotation
- 2 MY025PE 10 k Ω continuous rotation
- 3 MY035PE 2.2 k Ω continuous rotation
- 4 MY030PE MCB 10 k Ω
- 5 MY031PE MCB 10 k Ω continuous rotation

Male coupling



Female coupling



Flange

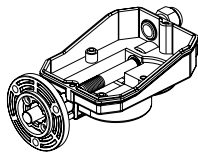

Potentiometer / Encoder

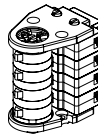
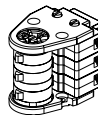
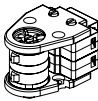
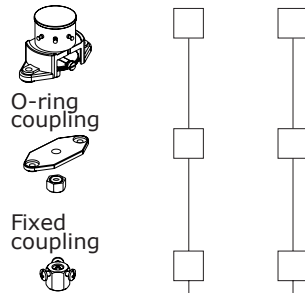

Revolution ratio

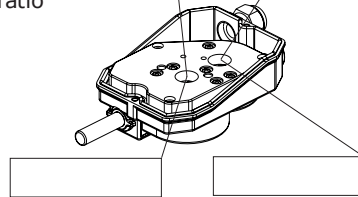

Cover

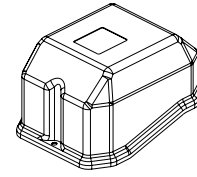

Standard shaft

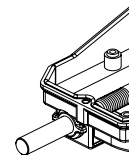

Flexible shaft

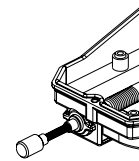

Pinion gears

- 1 MY911PI M10 Z12
- 2 MY912PI M12 Z10
- 3 MY913PI M14 Z10
- 4 MY914PI M16 Z10
- 5 MY915PI M20 Z8
- 6 MY916PI M5 Z12
- 7 MY917PI M6 Z11
- 8 MY918PI M8 Z12
- 9 MY944PI M12 Z12

Pinion gear

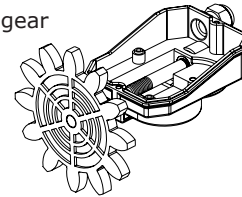

Instructions

- Mark the boxes corresponding to the components required.
- Write the numbers corresponding to the **cams**, the **switches**, the **pinion gear** and the **potentiometers** required.
- When a potentiometer is required, mark the box corresponding to the type of **coupling** needed.
- Write the **revolution ratio** required for each output.

Remarks

Use and Maintenance Instructions

The RLS4C rotary limit switch is an electromechanical device for low voltage control circuits (EN 60947-1, EN 60947-5-1) to be used as electrical equipment on machines (EN 60204-1) in compliance with the fundamental requirements of the Low Voltage Directive 73/23/CEE and of the Machine Directive 89/392/CEE.

The limit switch is designed for industrial use and also for use under particularly severe climatic conditions (operational temperature from -25°C to $+70^{\circ}\text{C}$, suitable for use in tropical environment). The equipment is not suitable for use in environments with potentially explosive atmosphere, corrosive agents or a high percentage of sodium chloride (saline fog). Oils, acids or solvents may damage the equipment. Use the fixing holes on the base or the flange (47) to mount the limit switch. The use of special couplings (49, 51), flexible shafts or special driving systems (not supplied) are recommended for eliminating any misalignment between the limit switch shaft (54, 61) and the reduction gear shaft to which it is connected. After loosening the central screw (03) use the screws (09, 10, 12, 13) to adjust the operating point of the cams (08); once the cams are adjusted, tighten the central screw (03).

The switches (07) are designed for auxiliary control of contactors or electromagnetic loads (utilisation category AC-15 according to EN 60947-5-1). The switches (07) have positive opening operation contacts (EN 60947-5-1). Do not connect more than one phase to each switch (07). Do not oil or grease the control elements (08) or the switches (07). For easy wiring, the set of cams/switches (35) may be removed by loosening the screws (15) on the lower fixing plate; do not loosen the screws (01) on the upper part of the set of cams/switches in order not to take apart the switches; after wiring is completed, the set of cams/switches (35) must be properly fixed and screwed, paying attention to the coupling of the hexagonal plastic bushes (14, 38).

The installation of the limit switch shall be carried out by an expert and trained personnel. Wiring shall be properly done according to the current instructions.

Prior to the installation and the maintenance of the limit switch, the main power of the machinery shall be turned off.

Steps for the proper installation of the limit switch

- loosen the fixing screw (32) and remove the cover (33)
- connect the limit switch shaft (54, 61) to the reduction gear shaft; to avoid any misalignment between the two shafts the use of couplings (49, 51), flexible shafts or special driving systems is recommended
- fix the limit switch firmly in place to prevent abnormal vibrations of the equipment during operation; use only the fixing holes on the base or the flange (47) to fix the equipment
- insert the cable into the limit switch through the cable clamp (41)
- strip the cable to a length suitable for wiring the switches (07)
- tape the stripped part of the cable
- clamp the wire into the cable clamp (41)
- connect all the switches (07) according to the contact scheme printed on the switches (tighten the wires into the terminals with a torque equal to 0.8 Nm; insertability of wires into the switch terminals equal to $2 \times 1.5 \text{ mm}^2 - 1 \times 2.5 \text{ mm}^2$)
- adjust the operating point of the cams (08); for proper adjustment, loosen the central screw (03) of the cam set, adjust the operating point of each single cam (08) by turning its screw (09, 10, 12, 13) (the numbers on the screws refer to the cams counting from bottom to top), then tighten the central screw (03)
- close the limit switch checking the proper positioning of the rubber (34) in the cover (33)

Periodic maintenance steps

- check the proper tightening of the screws (32) and cover (33)
- check the proper tightening of the switch (07) terminal screws
- check the proper tightening of the central screw (03) holding the cams (08)
- check the wiring conditions (in particular where wires clamp into the switch)
- check the proper positioning of the front (52) and rear (42) bush covers
- check the conditions of the rubber (34) fit into the cover (33) and check the tightening of the cable clamp (41) around the cable
- check that the limit switch enclosure (33, 43, 44) is not broken
- check the alignment between the limit switch shaft (54, 61) and the reduction gear shaft
- check that the limit switch is properly fixed

In case any component of the limit switch is modified, the validity of the markings and the guarantee on the equipment are annulled. Should any component need replacement, use original spare parts only.

MEYLE declines all responsibility for damages caused by the improper use or installation of the equipment.