

- Absolute single- and multiturn encoders with Bit Parallel, SSI, Profibus, CAN, DeviceNet, Interbus and Ethernet outputs
- Shaft and blind shaft 58 mm diameter versions
- Aluminium flange and housing
- Stainless steel shaft
- Precision ball bearings with sealing or cover rings
- Code disc made of unbreakable and durable plastic
- Applications: Sensing of
  - Angels
  - Distances
  - Tracks
  - Inclinations
  - Differences between two or more axes
- Compact and heavy-duty industrial types
- Housing: 58 mm Ø
- Shaft: 6 or 10 mm Ø, blind shaft 8-15 mm Ø with reduction hub, hollow shaft 12 mm Ø
- Max. 65,536 steps per revolution (16 bit)
- Max. 16,384 revolution (14 bit)
- EMC: EN61000-6-2, EN61000-6-4, CE
- Interface:
  - SSI (RS 422/485)
  - Bit parallel, push pull
  - Profibus DP
  - CAN, CANopen
  - Interbus
  - Device Net
  - Ethernet



DeviceNet™

PROFIBUS

CANopen



SSI  
ETHERNET



## Electrical Data:

	SSI	Parallel	Profibus (other Bus-Interfaces on request)
Outputs/Interface	Driver RS 485 / RS 422 Transfer distance up to 1200 mm Transmission rate up to 10 MBaud	Bit-parallel, push pull (max. 20 mA each channel)	Line-driver according to RS 485, galvanically isolated by opto-couplers (max. 12 MBaud Transmission rate)
Clock input/frequency	Via opto-coupler / 100 kHz-1 MHz		
Supply voltage	10-30 V DC	10-30 V DC	10-30 V DC
Current consumption	Version SL max. 1 W, version S1 max 1.5 W, version S2 max. 1.5 W, version S3 max. 2.2 W	max. 400 mA (10 V DC), max. 180 mA (24 V DC)	max. 230 mA with 10 V DC, max. 100 mA with 24 V DC
Output code	Binary or Gray	Binary or Gray	Binary
Singleturn resolution	(10, 11), 12, 13, 16 Bits	(10, 11), 12, 13, 16 Bits	(10, 11), 12, 13, 16 Bits
Multiturn resolution	12, 14 Bits	4, 8, 12, 14 Bits	12, 14 Bits
Incremental signals optional	Line driver RS 422		
Number of increments	1024, Channel A, $\bar{A}$ , B, $\bar{B}$		
Accuracy of division	$\pm 1/2$ LSB (12 bit), $\pm 2$ LSB (16 bit)	$\pm 1/2$ LSB (12 bit), $\pm 2$ LSB (16 bit)	$\pm 1/2$ LSB (12 bit), $\pm 2$ LSB (16 bit)
Internal cycle time		< 3 $\mu$ s	
Step frequency LSB	Max. 800 kHz (valid code)	12 Bit Resolution up to 12 000 rpm 16 Bit Resolution up to 1 000 rpm	800 kHz
Connection	Connector or cable exit 1 meter	Connector or cable exit 1 meter	Bus cover
Optional	Built-in RS 485 / 422 interface for bus mode (strobe-function) Up to 32 encoders can be used on the same data line!	Binary code transmission with integrated latch function	

Mechanical Data:	SSI	Parallel	Profibus / CANopen (other Bus-Interfaces on request)													
Housing	Aluminium, optional stainless steel	Aluminium, optional stainless steel	Aluminium, optional stainless steel													
Max. shaft loading	Axial 40 N, radial 110 N	Axial 40 N, radial 110 N	Axial 40 N, radial 110 N													
Inertia of rotor	≤ 30 gcm <sup>2</sup>	≈ 30 gcm <sup>2</sup>	≤ 30 gcm <sup>2</sup>													
Friction torque	≤ 3 Ncm (without shaft sealing)	≤ 3 Ncm (without shaft sealing)	≤ 3 Ncm (without shaft sealing)													
RPM (continuous operation)	Single turn: max. 12 000 rpm Multi turn: max. 6 000 rpm	Single turn: max. 12 000 rpm Multi turn: max. 6 000 rpm	Single turn: max. 12 000 rpm Multi turn: max. 6 000 rpm													
Shock (EN 60068-2-27)	≤ 100 g (halfsine, 6 ms)	≤ 100 g (halfsine, 6 ms)	≤ 100 g (halfsine, 6 ms)													
Permanent shock (EN 60068-2-29)	≤ 10 g (halfsine, 16 ms)	≤ 10 g (halfsine, 16 ms)	≤ 10 g (halfsine, 16 ms)													
Vibration (EN 60068-2-6)	≤ 10 g (10 Hz...1 000 Hz)	≤ 10 g (10 Hz...1 000 Hz)	≤ 10 g (10 Hz...1 000 Hz)													
Weight (standard version)	Single turn: ≈ 200 g Multi turn: ≈ 300 g	Single turn: ≈ 200 g Multi turn: ≈ 300 g	Single turn: ≈ 550 g Multi turn: ≈ 600 g													
Weight (stainless steel version)	Single turn: ≈ 400 g Multi turn: ≈ 600 g	Single turn: ≈ 400 g Multi turn: ≈ 600 g	Single turn: ≈ 1100 g Multi turn: ≈ 1200 g													
<b>Flange</b>	<b>Synchro (S)</b>	<b>Clamp (C)</b>	<b>Blind shaft (B)</b>	<b>Synchro (S)</b>	<b>Clamp (C)</b>	<b>Blind shaft (B)</b>	<b>Synchro (S)</b>	<b>Clamp (C)</b>	<b>Blind shaft (B)</b>							
Shaft diameter	mm	6	10	10	15	8, 10, 12 (with hub)	6	10	10	15	8, 10, 12 (with hub)	6	10	10	15	
Shaft length	mm	10	20	20	–	–	10	20	20	–	–	10	20	20	–	
Hollow shaft depth min./max.	mm	–	–	–	15/30	–	–	–	–	15/30	–	–	–	–	15/30	
<b>Environmental Conditions</b>																
Working temperature	– 40 °C...+ 85 °C	– 30 °C...+ 70 °C	– 40 °C...+ 85 °C	– 40 °C...+ 85 °C												
Storage temperature	– 40 °C...+ 85 °C	– 40 °C...+ 85 °C	– 40 °C...+ 85 °C	– 40 °C...+ 85 °C												
Humidity	98 % (non condensing)	98 % (non condensing)	98 % (non condensing)	98 % (non condensing)												
Protection Class (EN 60529)	Housing side: IP 65 Shaft side: IP 64 (optional with shaft sealing: IP 66)	Housing side: IP 65 Shaft side: IP 64 (optional with shaft sealing: IP 66)	Housing side: IP 65 Shaft side: IP 64 (optional with shaft sealing: IP 66)	Housing side: IP 65 Shaft side: IP 64 (optional with shaft sealing: IP 66)												

## Mechanical Drawings SSI, Parallel Output

Synchro flange (S)  
Cable exit

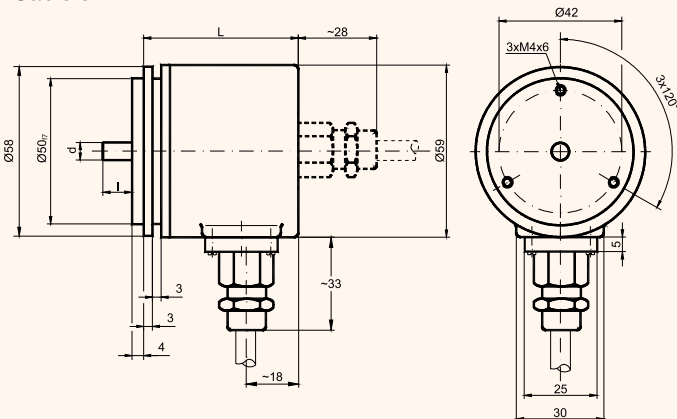

Connector exit

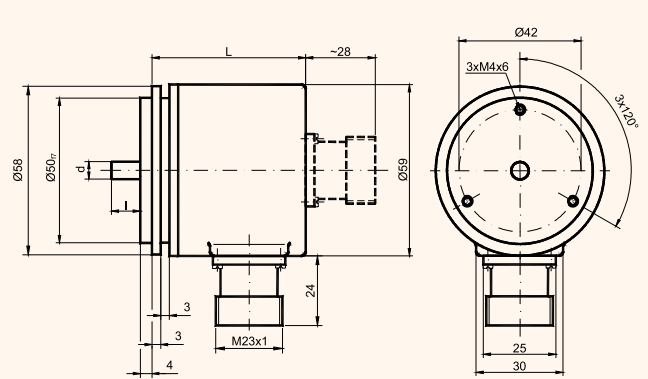

Synchro flange	d / mm	l / mm
Version S06	6 <sub>f6</sub>	10
Version S10	10 <sub>f8</sub>	20

## Mechanical Drawings SSI, Parallel Output

Clamp flange (C)

Cable exit

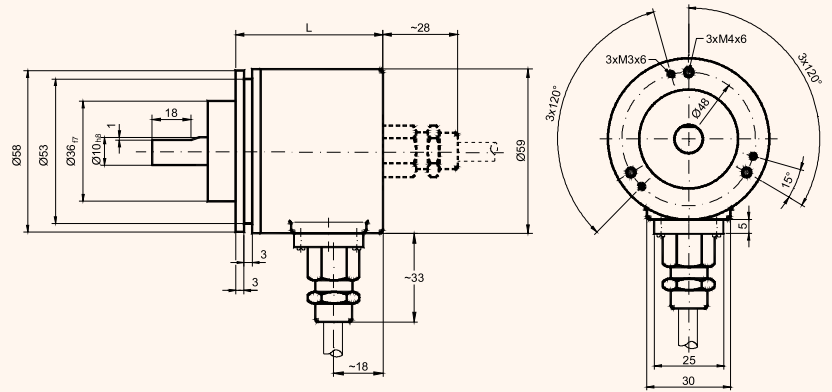

Connector exit

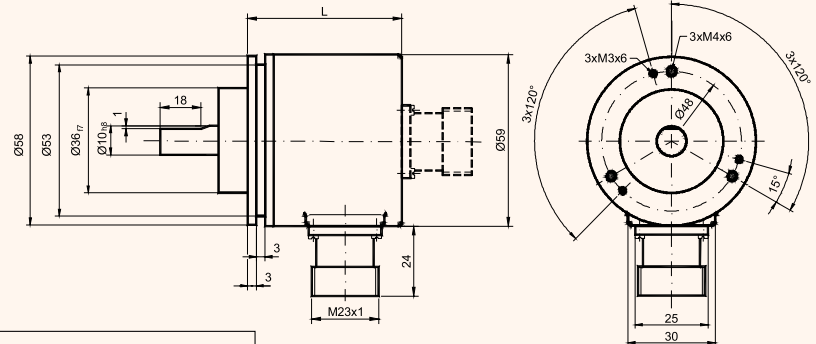

		L			
		SSI	SSI Preset	Parallel	Parallel Preset
Single turn	axial cable / connector	42	53	42	53
	radial cable	53	53	53	53
	radial connector	53	53	53	53
Multi turn	axial cable / connector	62	62	-	53
	radial cable	54	62	-	53
	radial connector	54	62	-	78

Connector height

SSI	M23 x 1	Length axial = 28 mm
		Length radial = 24 mm
Parallel ≤ 13 Bit	M23 x 1	Length axial = 28 mm
		Length radial = 24 mm
Parallel 14-21 Bit	M27 x 1	Length axial = 23 mm
		Length radial = 31 mm

Blind Shaft (B)

Connector exit

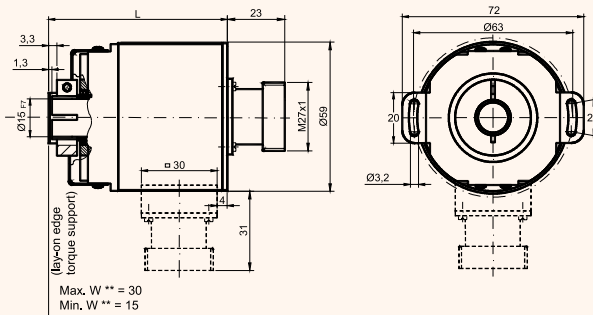

Cable exit

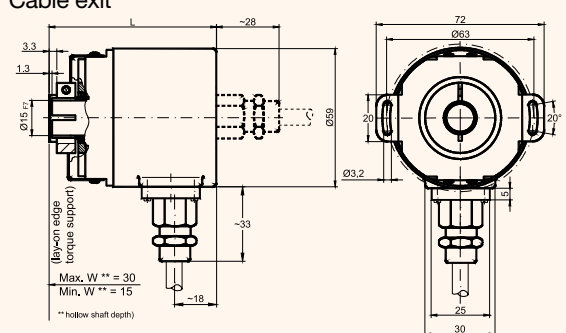

		L			
		SSI	SSI Preset	Parallel	Parallel Preset
Single turn	axial cable / connector	61	72	61	72
	radial cable	72	72	72	72
	radial connector	72	72	72	72
Multi turn	axial cable / connector	81	81	-	71
	radial cable	73	81	-	71
	radial connector	73	81	-	96

Connector exit (only for 21 Bit)

SSI	1123 x 1	Length axial = 28 mm
		Length radial = 24 mm
Parallel ≤ 13 Bit	1123 x 1	Length axial = 28 mm
		Length radial = 24 mm
Parallel 14-21 Bit	1127 x 1	Length axial = 23 mm
		Length radial = 31 mm

## Mechanical Drawings Profibus

### Synchro flange (S)

Synchro flange	d / mm	l / mm
Version S06	$\text{Ø}6_{f6}$	10
Version S10	$\text{Ø}10_{h8}$	20

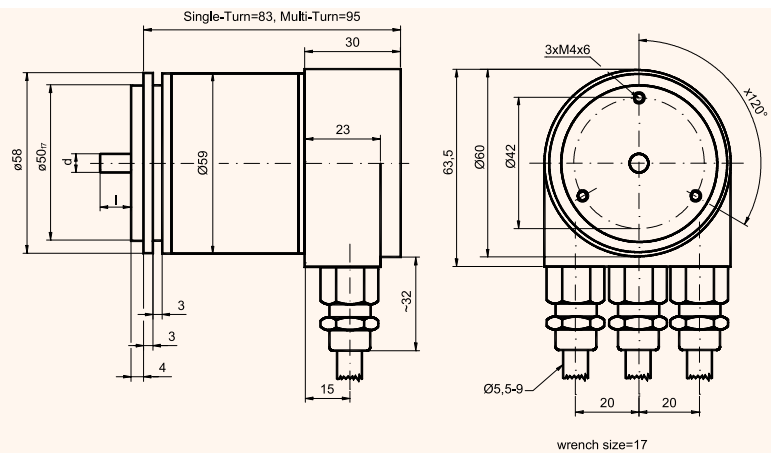

### Camp flange (C)

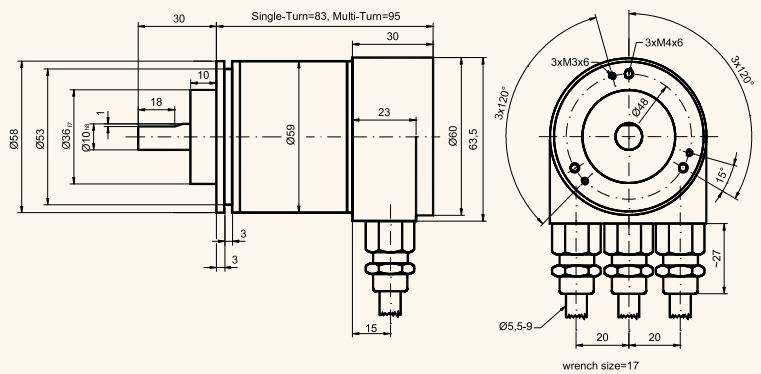

### Blind shaft (B)

#### Mounting instructions

The clamp ring may only be tightened if the shaft of the driving elements is in the hollow shaft.

The diameter of the hollow shaft can be reduced to 12 mm, 10 mm or 8 mm by using an adapter (this reducing adapter can be pushed into the hollow shaft).

Allowed shaft movements of the drive element are listed in the table.

	axial	radial
static	$\pm 0.3$ mm	$\pm 0.5$ mm
dynamic	$\pm 0.1$ mm	$\pm 0.2$ mm

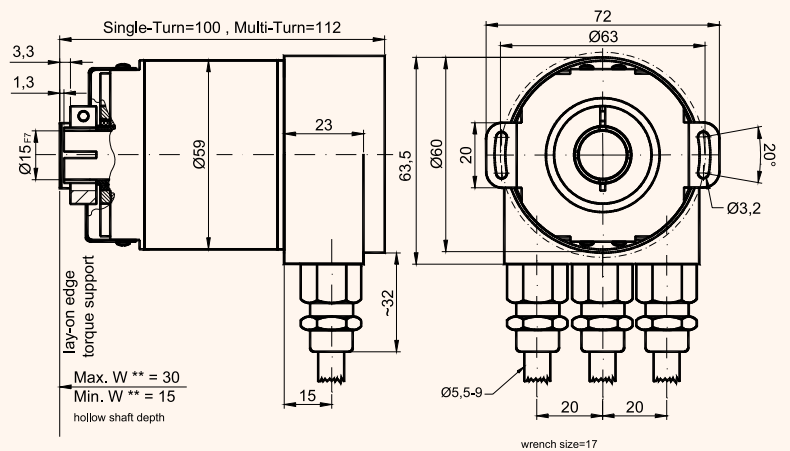

Drawing EASH58 / SSI / Parallel / Bus-Interfaces - Absolute singleturn hollow shaft encoder

Hollow shaft (H)

12 pol. Connector (for  $\varnothing$  6-9 mm cable)

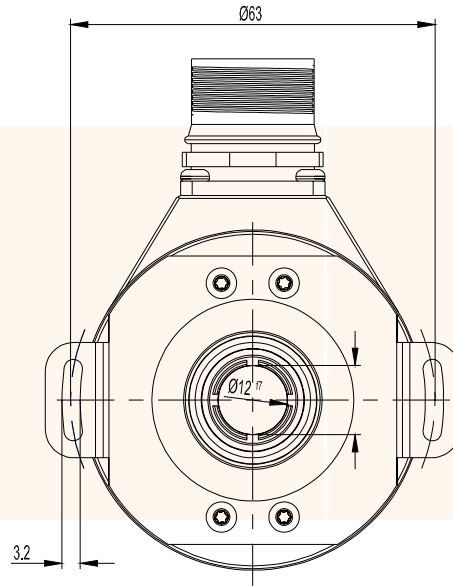
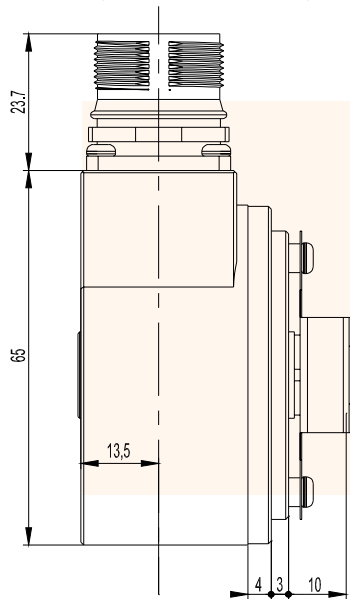

Cable exit (Cable =  $\varnothing$  8 mm )

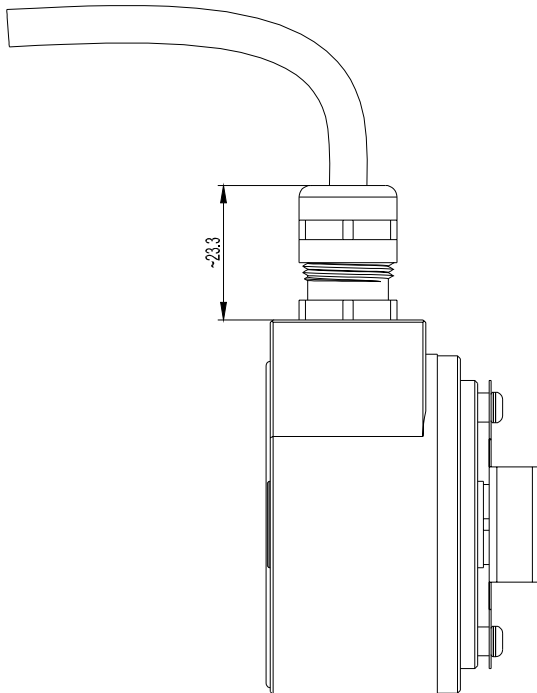

	L
Single-Turn	47
Multi-Turn	60

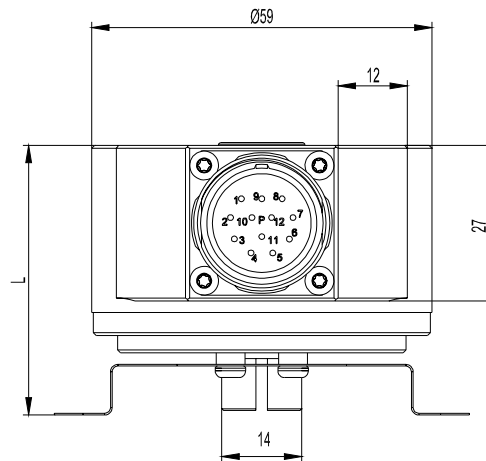

**CANopen specification EASx58 - Absolute singleturn encoder**

**Interface**

**Configuration**

The standard configuration of the encoder is: node number 32 and baudrate 20KBaud. For adapting the encoder for a respective application the customer could use SDO telegrams. Valid baudrate range is 20 kBaud up to 1MBaud and for the node number from 0 to 89.

**Remark: The encoder adds internal 1 to the adjusted device address.**

**Electrical Interface**

There are various electrical connecting options like 5 pin M12 connector. The encoder can be connected in the following versions:

- 5 pin M12 male connector and one 5 pin M12 male
- 5 pin M12 connector and venting element
- 9 pin D-Sub connector or cable exit (not available for Heavy Duty version)

	9 pin D-Sub (Not available for HD-version and radial exit)	5 pin M12	open cable
Signal	Pin	Pin	
(CAN Ground)	3	1	green
24 V power supply	9	2	white
0 V power supply	6	3	brown
CAN High	7	4	yellow
CAN Low	2	5	pink

**Bus In socket / cable output connector**

9 pin D-Sub connector / cable + 15 pin D-Sub connector

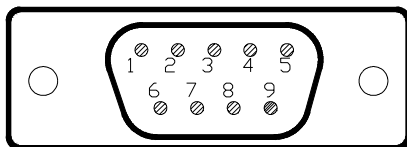

**Bus In**

5 pin M12 connector male

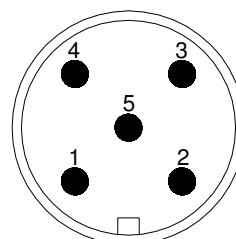

**CANopen specification EASx58 - Absolute singleturn hollow shaft encoder****Programmable Encoder - Parameter**

Operating Parameters	This parameter determines the counting direction, in which the output code increases or decreases. As an important operating parameter the code sequence (complement) can be programmed.
Resolution per Revolution	The parameter resolution per revolution is used to program the desired number of steps per revolution.
Total Resolution	This parameter is used to program the desired number of measuring units over the total measuring range. This value may not exceed the total resolution of the absolute rotary encoder. If the encoder is used in a continuous measuring application, certain rules for the setting of this parameter must be followed. These rules are outlined in the manual.
Preset Value	The preset value is the desired position value, which should be reached at a certain physical position of the axis. The position value is set to the desired process value by the parameter pre-set.
Limit Switch, Min. and Max.	Two position values can be programmed as limit switches. By reaching these values one bit of the 32-bit process value is set to high.
Cam	Eight position values can be programmed as cams. By reaching these values bits in object 6300h Cam state register are set.

**Programmable CAN Transmission Modes**

Polled Mode	By a remote-transmission-request telegram the connected host calls for the current process value. The absolute rotary encoder reads the current position value, calculates eventually set-parameters and sends back the obtained process value by the same identifier.
Cyclic Mode	The absolute rotary encoder transmits cyclically - without being called by the host - the current process value. The cycle time can be programmed in milliseconds for values between 1 ms and 65536 ms.
Sync Mode	After receiving a sync telegram by the host, the absolute rotary encoder answers with the current process value. If more than one node number (encoder) shall answer after receiving a sync telegram, the answer telegrams of the nodes will be received by the host in order of their node numbers. The programming of an offset-time is not necessary. If a node should not answer after each sync telegram on the CAN network, the parameter sync counter can be programmed to skip a certain number of sync telegrams before answering again.

## ORDERING CODE SSI

	Interface	Code	Resolution	Flange	Shaft diameter	Mechanical options	Connection
<b>EASS58</b> Absolute singleturn shaft encoder	SL = SSI S1 = SSI + Preset S2 = SSI + Inkr.	G = Gray B = Binary	(0010 = 10 Bit ST) (0011 = 11 Bit ST) 0012 = 12 Bit ST 0013 = 13 Bit ST 0016 = 16 Bit ST (1210 = 12 Bit MT + 10 Bit ST) (1211 = 12 Bit MT + 11 Bit ST) 1212 = 12 Bit MT + 12 Bit ST 1213 = 12 Bit MT + 13 Bit ST 1216 = 12 Bit MT + 16 Bit ST (1410 = 14 Bit MT + 10 Bit ST) (1411 = 14 Bit MT + 11 Bit ST) 1412 = 14 Bit MT + 12 Bit ST 1413 = 14 Bit MT + 13 Bit ST 1416 = 14 Bit MT + 16 Bit ST	C = Clamp flange S = Synchro flange B = Blind shaft	06 = 6 mm 10 = 10 mm 12 = 12 mm (Hollow shaft) 15 = 15 mm (Blind shaft)	O = Without S = Shaft sealing (IP 66) V = Stainless steel	8A = Connector axial 8R = Connector radial 3A = 1 m cable exit, axial 3R = 1 m cable exit, radial*
<b>EAMS58</b> Absolute multiturn shaft encoder							
<b>EASB58</b> Absolute singleturn blind shaft encoder							
<b>EAMB58 / EAMH58</b> Absolute multiturn blind (B) / hollow (H) shaft encoder							

\* not in stainless steel version  
ST = Single turn  
MT = Multi turn

## ORDERING CODE PARALLEL INTERFACE

	Interface	Code	Resolution	Flange	Shaft diameter	Mechanical options	Connection
<b>EASS58</b> Absolute singleturn shaft encoder	P1 = push pull reset	G = Gray B = Binary	(0010 = 10 Bit ST) (0011 = 11 Bit ST) 0012 = 12 Bit ST 0013 = 13 Bit ST 0016 = 16 Bit ST 0360 = 360 increments ST (0410 = 4 Bit MT + 10 Bit ST) (0411 = 4 Bit MT + 11 Bit ST) 0412 = 4 Bit MT + 12 Bit ST 0413 = 4 Bit MT + 13 Bit ST 0416 = 4 Bit MT + 16 Bit ST (0810 = 8 Bit MT + 10 Bit ST) (0811 = 8 Bit MT + 11 Bit ST) 0812 = 8 Bit MT + 12 Bit ST 0813 = 8 Bit MT + 13 Bit ST 0816 = 8 Bit MT + 16 Bit ST (1210 = 12 Bit MT + 10 Bit ST) (1211 = 12 Bit MT + 11 Bit ST) 1212 = 12 Bit MT + 12 Bit ST 1213 = 12 Bit MT + 13 Bit ST (1410 = 14 Bit MT + 10 Bit ST) (1411 = 14 Bit MT + 11 Bit ST)	C = Clamp flange S = Synchro flange B = Blind shaft	06 = 6 mm 10 = 10 mm 12 = 12 mm (Hollow shaft) 15 = 15 mm (Blind shaft)	O = Without S = Shaft sealing V = Stainless steel (only axial exit possible)	26A = Connector*** axial, max. 21 bit 26R = Connector*** radial, max. 21 bit** 3A = 1 m cable exit, axial, max. 25 bit 3R = 1 m cable exit, radial, max. 25 bit**
<b>EAMS58</b> Absolute multiturn shaft encoder							
<b>EASB58</b> Absolute singleturn blind shaft encoder							
<b>EAMB58 / EAMH58</b> Absolute multiturn blind (B) / hollow (H) shaft encoder							

\* total Resolution on connector exit max. 21 bit, on cable exit max. 25 bit  
\*\* not in stainless steel version  
\*\*\* ST <14 bit: connector 16 pin (16A / 16R)  
ST = Single turn  
MT = Multi turn

## ORDERING CODE PROFIBUS-DP / CANopen

	Interface	Code	Resolution	Flange	Shaft diameter	Mechanical options	Connection
<b>EASS58</b> Absolute singleturn shaft encoder	DP = Profibus CO = CANopen	B = Binary	(0010 = 10 Bit ST) (0011 = 11 Bit ST) 0012 = 12 Bit ST 0013 = 13 Bit ST 0016 = 16 Bit ST (1210 = 12 Bit MT + 10 Bit ST) (1211 = 12 Bit MT + 11 Bit ST) 1212 = 12 Bit MT + 12 Bit ST 1213 = 12 Bit MT + 13 Bit ST 1216 = 12 Bit MT + 16 Bit ST (1410 = 14 Bit MT + 10 Bit ST) (1411 = 14 Bit MT + 11 Bit ST) 1412 = 14 Bit MT + 12 Bit ST 1413 = 14 Bit MT + 13 Bit ST 1416 = 14 Bit MT + 16 Bit ST	C = Clamp flange S = Synchro flange B = Blind shaft H = Hollow shaft	06 = 6 mm 10 = 10 mm 12 = 12 mm (Hollow shaft) 15 = 15 mm (Blind shaft)	O = Without S = Shaft sealing (IP 66) V = Stainless steel version	Z = Bus Cover to be ordered separately B = cable radial, 2 m PVC w/o bus cover, D-Sub
<b>EAMS58</b> Absolute multiturn shaft encoder							
<b>EASB58</b> Absolute singleturn blind shaft encoder							
<b>EAMB58 / EAMH58</b> Absolute multiturn blind (B) / hollow (H) shaft encoder							

ST = Single turn  
MT = Multi turn